



Consumer Solutions

**Extrusion of XIAMETER™ High
Consistency Silicone Rubber**
Product Guide

XIAMETER™



Extrusion of XIAMETER™ High Consistency Silicone Rubber

XIAMETER™ silicone rubber is extruded to make tubing, rods, gaskets, seals, wire insulation, and preforms used in compression molding. With this process, the rubber is continuously forced through a die that forms it to the desired cross-sectional size and shape. Although the general procedure is the same as for organic rubber, there are detailed differences. The following sections cover basic facts on extruding silicone rubber.

Screw Extruders

Screw extruders used with silicone rubber should have the following equipment:

- A screw designed for silicone rubber.
- A feeding roller attached to the screw by a gear or separately driven in the intake zone.
- An extended barrel, suited to the length of the screw. The barrel should be hard metal plated.
- A breaker plate with recess to hold screens that will produce enough pressure in the rubber to ensure removal of trapped air fitted with A 60 to 120 mesh stainless steel screen.
- A spider flange or crosshead to (a) hold a mandrel for forming the inside diameter when making tubing, and (b) hold the die holder and permit radial adjustment for centring.
- A universal die holder.
- A coin or plate die.

Screw Design

For good extrusion work with silicone rubber, it is important to have a screw of proper design. A single flight screw with diminishing pitch is best. Typically (length-to-diameter) ratio of 10:1 to 12:1 is used. The screw should have a compression rate of 1:1.5 to 1:2, which can be obtained with constant core diameter and varying flight distance or with varying core diameter and constant flight distance. For troublefree continuous feeding and high output, the flight should be quite deep and should be hardened or hard metal coated to prevent wear. The screw should be well cooled to prevent scorch due to the shear heat generated during the extrusion process. For improved consistency of volume output some manufacturers recommend to use double flights in the output area of the screw.

Roller Feed

A roller feed to the extruder, with the rubber fed from a “hat” or coil, ensures a more uniform extrusion than hand feeding, and saves considerable labor. When rubber is roller-fed from a “hat” the coil support should be horizontal and mounted close to the feed roller.



Fig. 1: Screw design of a flight progressive screw for silicone rubber extrusion

Gear Extruders

Gear pumps have been used since 15 years to improve output consistency of screw extruders and to increase the die pressure, mainly for thermoplastics. Recently the principle of the gear pump has been used by several machine manufacturers as independent, highly effective rubber extrusion unit. The gear pump is fitted with two feeding rolls at the entrance side. Advantages of this layout compared to screw extruders are a significantly lower energy consumption, more compact design to save production space, a very low shear inside the machine with a low buildup of heat, minimizing the risk of scorch, and a very constant output. Disadvantage is that air entrapments in the raw material are not removed and the material homogenization is low so that the requirements to the uniformity of the raw materials is very high.

Extrusion Dies

Mandrel

In extruding tubing, the ID (inside diameter) is formed by a mandrel, which is held by the spider flange. To keep thin wall tubing round during vulcanization, the flange and mandrel are drilled to admit air under light pressure – from less than 7kPa to about 35kPa, depending on tube diameter and wall thickness.

Die Design Principles

Coin or plate dies work well for silicone rubber extrusions. The following pointers will be of value in designing good dies:

- There should be no “dead spots” to catch and hold the rubber as it approaches the die. If a quantity of silicone rubber is trapped in the extruder for an extended period, frictional heat may cause it to vulcanize. This will result in restricted flow, rough extrusions, or other troubles.

Tapered inserts are often used to eliminate “dead spots” Silicone rubber normally swells as it leaves the die; so the die opening ordinarily must be somewhat smaller than the size desired in the extrusion. It is well to remember that shrinkage during vulcanization and curing will partially compensate for this die swell. In addition, the cross-section of the extrusion may be reduced by stretching the unsupported portion between the die and the vulcanizing chamber.

- Flow of silicone rubber should be uniform through all parts of the die. Sharp corners in the die tend to produce excessive drag, resulting in rough edges on the extrusion. This effect can be overcome by putting a slight radius on all corners. Non-uniform flow also results when some parts of the die opening are smaller than others in a cross-sectional area. This can be corrected by providing a shorter land at the constriction. The land is shortened by drilling or machining away part of the thickness of the die (see Figs. 2 and 3). Conversely, uniform flow can be obtained by slowing the flow through large openings in the die. This is done by installing a dam on the screw side of the die to retard the flow.
- Dies should be designed so that corrections or adjustments can be easily made. Figs. 4 and 5, for example, show dies with adjustable dams to vary the rate of flow.

Extrusion Characteristics of Silicone Rubber

XIAMETER™ silicone rubber should be extruded at room temperature. In fact, it should not be allowed to reach a temperature above 54°C during extrusion, since higher temperatures may produce scorching and loss of vulcanizing agent.

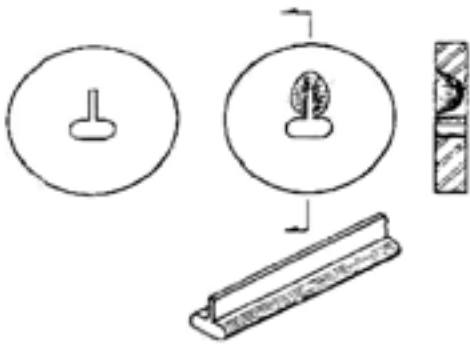

Fig. 2. Die for bulb-type extrusion is machined to have a short land where the thin leg is extruded. This provides the same rate of flow for the thin section as for the heavy section. Another method of balancing flow is shown in Fig. 4 and 5.

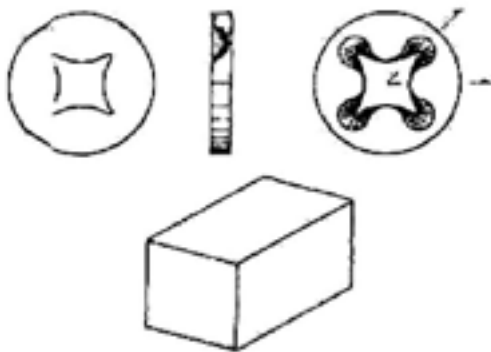

Fig. 3. Die for making square extrusion. Sides of die opening are made convex so that straight sides are formed as the silicone rubber swells upon leaving the die; and corners have a slight radius to help obtain smooth corners on the extrusion. Rear and sectional views show how part of die has been cut away to provide short land at corners to balance the flow of rubber.

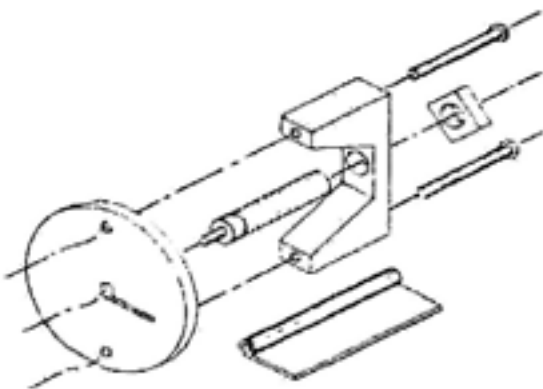

Fig. 4. In this die for a "p" gasket, hole in "p" is formed by pin mounted on bridge. Rate of flow in thick and thin sections of extrusions is balanced by shoulder dam behind small-diameter section of pin. Pin can be positioned along its axis to adjust the rate of flow to suit the rubber used.



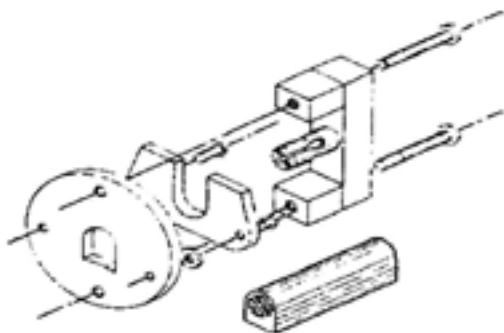

Fig. 5. In this die for a seal, a dam or baffle plate restricts the flow at heavy section of extrusion, to obtain uniform flow for all sections. Here, the rubber must flow between die plate and dam to fill the heavy section. Clearance between dam and die plate can be adjusted as required for different rubber.

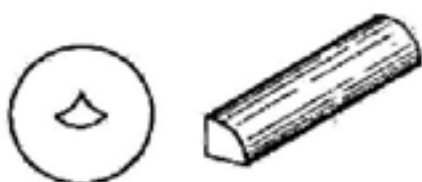

Fig. 6. In die for extruding quarter-round seal, die opening has convex sides to give straight sides on the right-angle portion, and corners have a slight radius to help obtain smooth corners on extrusion.

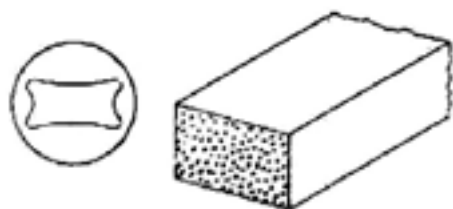

Fig. 7. Die for extruding sponge of square cross-section. Dies for sponge must allow for expansion during blowing (sponge formation) in addition to the expansion that is normal in solid extrusions.

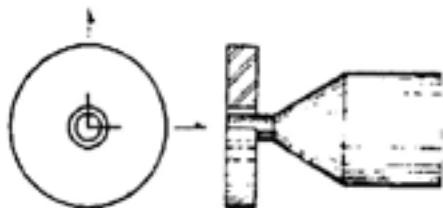

Fig. 8. Die and mandrel for extruding silicone rubber tubing. Mandrel tip is replaceable for easy change of ID of tubing.

Vulcanizing Methods and Equipment

The following paragraphs cover methods and equipment used in vulcanizing extrusions. The vulcanizing agents, their effects on properties of the finished product, and related matters are discussed in the section on vulcanizing.

Hot Air Vulcanizing

This a continuous process, and is the most frequently used method of vulcanizing extrusions. The extrusion is passed through a horizontal chamber heated to 250-500°C or a vertical chamber heated up to 700°C. Extrusions of small cross section require only a few seconds to vulcanize at these temperatures, those of larger cross section require proportionately longer time.

In horizontal HAV (hot-air-vulcanizing) units, the extrusion is carried on a steel or wire-mesh conveyor belt from the extruder through the vulcanizing chamber. In vertical units, the extrusion is dropped downwards by its own weight or pulled upwards through the chamber by a motor-driven drum at the top. In the latter case extrusion is sufficiently vulcanized in the entry area of the chamber to prevent excessive stretching, and as it moves up through the chamber, it continues to vulcanize, gaining strength enough to hold the weight of the material below with little change in dimensions even for heavy profiles.

With both horizontal and vertical units, the size of the unsupported loop of extrusion between the extruder and the vulcanizing chamber should be held constant, to maintain uniformity of cross section.

Both horizontal and vertical vulcanizing chambers can be heated by strip heaters, infrared units, heating mantles, or any other clean heat source. In addition horizontal chambers can be heated with an airstream providing a very fast and efficient heat transfer. The air is heated, and is then blown into the chamber to create turbulence. This provides much faster heat transfer than a static atmosphere. The heating can be electrically or with natural gas heating. To save energy, part of the air stream can be conducted in a circulating system.

All vulcanizing chambers should have an air exhaust system to assure proper removal of volatiles.

Horizontal HAV units are most widely used, and are best suited to extrusions that have one or more flat sides. Vertical units are best for making thin-walled tubing, since there can be no flattening in a vertical unit before vulcanization is complete. In addition, with no conveyor belt, vertical units provide uniform heating around the extrusion, assuring rapid and uniform vulcanization. Thus, in making solid and tubular sponge, they provide a uniform cell size throughout the cross section. They also prevent "snaking" while vulcanizing; and, of course, they produce no belt marks.

Salt Bath

The advantage of a salt bath is an excellent heat transfer and the lack of oxygen inhibition. A mixture of salts (KNO_3 , NaNO_3 , and NaNO_2) melting at 140° is used as heat transfer fluid to cure extruded silicone rubber. The extruded profile has to be kept under the surface of the molten salt by guiding rolls. The salt has to be removed of the profile after leaving the salt bath. Typically the profile needs washing, which leads to the requirement of salt recovery for environmental reasons.

Continuous Vulcanization in Steam (CV Cure)

For the production of cables a continuous vulcanization in steam is common. A pipe is attached to the extrusion die with a thermic separation, in which pressurized steam at 9 to 15 bar and 180 to 200 °C is blown. Typical length of the steam cure oven is 80 m or more. The wire inside is needed to support the cable in a horizontal CV cure.

Autoclave Vulcanizing

A steam autoclave is often used in vulcanizing small batches of extruded XIAMETER™ silicone rubber. Loosely coiled in a pan or tray, the extrusion is subjected to steam pressure to provide the required temperature for the required length of time, as determined by the rubber and the thickness of the extrusion.

Oven Curing

To attain the desired properties, most XIAMETER silicone rubber used for extrusions may need to be oven cured after vulcanizing.

In addition to the XIAMETER™ materials showcased in this guide, Dow offers a wide variety of SILASTIC™ specialty silicone and fluorosilicone elastomers, as well as service options to help you keep your innovative edge in the marketplace. Visit **consumer.dow.com** to learn more about additional options available from Dow.

www.xiameter.com

Image: dow_40145727176

LIMITED WARRANTY INFORMATION - PLEASE READ CAREFULLY

The information contained herein is offered in good faith and is believed to be accurate. However, because conditions and methods of use of our products are beyond our control, this information should not be used in substitution for customer's tests to ensure that our products are safe, effective and fully satisfactory for the intended end use. Suggestions of use shall not be taken as inducements to infringe any patent.

Dow's sole warranty is that our products will meet the sales specifications in effect at the time of shipment.

Your exclusive remedy for breach of such warranty is limited to refund of purchase price or replacement of any product shown to be other than as warranted.

TO THE FULLEST EXTENT PERMITTED BY APPLICABLE LAW, DOW SPECIFICALLY DISCLAIMS ANY OTHER EXPRESS OR IMPLIED WARRANTY OF FITNESS FOR A PARTICULAR PURPOSE OR MERCHANTABILITY.

DOW DISCLAIMS LIABILITY FOR ANY INCIDENTAL OR CONSEQUENTIAL DAMAGES.

®™ Trademark of The Dow Chemical Company ("Dow") or an affiliated company of Dow

© 2018 The Dow Chemical Company. All rights reserved.

30023848

Form No. 95-560-01 A