

BUILDING SCIENCE

Dow Construction Sealants Technical Manual

Americas

The Dow logo is a red diamond shape with the word "DOW" in white, bold, sans-serif capital letters inside. A small registered trademark symbol (®) is located to the right of the word.

DOW®



Dow Construction Sealants Technical Manual (Americas)

Table of Contents

Introduction	3
Technical Customer Service	3
Product Offering.....	4
Structural Glazing Sealants	4
Weatherproofing Sealants	5
Primers	6
Building Sealant Recommendations and Surface Preparation Guide for Weatherseal Applications.....	7
Silicone Structural Glazing	9
Introduction	9
Structural Joint Design	9
Structural Bite.....	10
Deadload	11
Sloped Glazing	12
Glueline Thickness.....	13
Structural Silicone Used in Shear.....	15
Structural Silicone Used in Seismic Applications.....	15
Splice Joints in Curtainwalls.....	16
Structural Glazing Guidelines	16
Substrate Suitability.....	17
Back-Painted Glass.....	18
Hot-Bent Curved Glass	18
Project Review Services.....	19
Product Recommendations.....	19
Classification of Silicone Structural Glazing.....	21
Application Methods for Structural Glazing Systems.....	23
Surface Preparation and Sealant Application.....	25
Replacement and Remedial Glazing	29
Quality Assurance – Structural Applications	29
Alternate Quality Control Tests	37
Documentation – Quality Assurance and Warranty.....	37
Weatherproofing.....	45
Introduction	45
Joint Movement	45
Joint Types.....	47
Joint Design	48
Moving Joint Considerations	48
Joint Movement in Shear	49
Movement During Cure	50
Backer Materials	50
Hydrophobic Effects	51
EIFS Considerations for Design and Specification	52
Weatherseal Design Examples	53
Weatherproofing Joints: Surface Preparation and Sealant Application	58
Removal and Replacement of Existing Weatherseals	62
Sealant Interaction Considerations	64
Quality Assurance – General	65
Appendix A: Cure Inhibition of DOWSIL™ 790 Silicone Building Sealant	72
Appendix B: Use of DOWSIL™ Sealants with Weathered Lock-Strip Gasket Systems	73
Appendix C: Winter/Summer Considerations	74
Appendix D: Adhesion of Silicone and Polyurethane Sealants	75

Dow Construction Sealants Technical Manual (Americas)

Introduction

This manual is intended to give guidance on proper application procedures and assist in the development of a quality assurance program for the application of DOWSIL™ silicone sealants for structural and weathersealing systems.

As construction projects vary in many aspects, such as design, customer requirements and environment, this manual cannot be considered a comprehensive quality assurance program for all situations.

Any review, recommendation or statement made on behalf of Dow relating to an engineering design, architectural drawing, product formulation, end-use specification or similar document is limited to the knowledge of product properties as determined by laboratory testing of material produced by Dow. Any comments or suggestions relating to any subject other than such product properties are offered only to call to the attention of the engineer, architect, formulator, end-user or other person considerations that may be relevant in his/her independent evaluation and determination of the appropriateness of such design, drawing, specifications, document or formula.

Dow assumes no responsibility for the comments or suggestions relative to subjects other than such product properties and expressly disclaims any warranty or responsibilities for them.

SITE ADHESION TESTING MUST BE VERIFIED ACCORDING TO THE CRITERIA ON PAGE 35 TO CONFIRM PROPER SURFACE PREPARATION PROCEDURES HAVE BEEN FOLLOWED.

Technical Customer Service

This service center provides a process and the resources to manage customers' product and technical information inquiries. This includes (but is not limited to): Environmental Health and Safety information, product recommendations, product troubleshooting, competitive cross-references, and application assistance. Inquiries are received via telephone and contact-us forms.

Telephone: + 1 800 258 2436, North America

Contact-us form: dow.com/contactus

Product Offering

Structural Glazing Sealants

Dow has a full line of high-performance silicone structural sealants. The following is a summary of each DOWSIL™ branded product offered for structural glazing applications. These sealants should be selected based upon the unique properties that each has for specific applications. Specific product information, such as physical properties, applications and limitations, can be found in data sheets available at dow.com/buildingscience.

DOWSIL™ 983 Structural Glazing Sealant

DOWSIL™ 983 Structural Glazing Sealant is a two-part, fast- and neutral-curing silicone sealant intended for structural bonding of glass, metal and other building components, as well as weatherseals in curtainwall units. DOWSIL™ 983 Structural Glazing Sealant cures to a high modulus sealant with excellent adhesion to a wide range of substrates. It is available in black and gray.

DOWSIL™ 995 Silicone Structural Sealant

DOWSIL™ 995 Silicone Structural Sealant is a one-part, medium modulus, neutral-curing silicone sealant with superior unprimed adhesion for structural glazing applications as well as weatherseals in curtainwall units.

DOWSIL™ 795 Silicone Building Sealant

DOWSIL™ 795 Silicone Building Sealant is a one-part, medium modulus, neutral-curing silicone sealant for structural glazing and weathersealing. It is available in a wide variety of colors.

DOWSIL™ 121 Structural Glazing Sealant

DOWSIL™ 121 Structural Glazing Sealant is a two-part, fast-cure, neutral-curing silicone sealant intended for structural bonding without the need of a two-part pump. It is ideal for repairs and/or replacement of structurally glazed glass and other substrates; and for on-site and in-shop structural glazing where the use of a two-part pump is not viable. It is supplied in dual-cartridge kits, and it is available in black and gray.



Weatherproofing Sealants

Dow has a full line of high-performance weatherproofing sealants. The following is a summary of each DOWSIL™ product offered for weatherproofing applications. These sealants should be selected based upon the unique properties that each has for specific applications. Specific product information, such as physical properties, applications and limitations, can be found in data sheets available at dow.com/construction.

DOWSIL™ 795 Silicone Building Sealant

DOWSIL™ 795 Silicone Building Sealant is a one-part, medium modulus, neutral-curing silicone sealant for structural glazing and weathersealing. It is available in a wide variety of colors.

DOWSIL™ 791 Silicone Weatherproofing Sealant

DOWSIL™ 791 Silicone Weatherproofing Sealant is a one-part, medium modulus, neutral-curing silicone sealant for general weathersealing applications. It is available in a wide variety of colors.

DOWSIL™ 790 Silicone Building Sealant

DOWSIL™ 790 Silicone Building Sealant is a one-part, low modulus, neutral-curing silicone sealant for use in high-movement weathersealing applications. DOWSIL™ 790 Silicone Building Sealant has excellent primerless adhesion to concrete and most porous substrates. It is available in a wide variety of colors.

DOWSIL™ Contractors Weatherproofing Sealant

DOWSIL™ Contractors Weatherproofing Sealant is a one-part, medium modulus, neutral-curing silicone sealant for use in non-specified, general weathersealing applications. It is available in a wide variety of colors.

DOWSIL™ Contractors Concrete Sealant

DOWSIL™ Contractors Concrete Sealant is a one-part, low modulus, neutral-curing silicone sealant for use in non-specified, general concrete weathersealing applications. It is available in a wide variety of colors.

DOWSIL™ 123 Silicone Seal and DOWSIL™ Silicone Seal Custom Designs H.C.

DOWSIL™ 123 Silicone Seal is a preformed, low modulus silicone extrusion that can be used as a bridge joint in a variety of applications, including restoration of failed sealant joints. Widths from 1" (25 mm) to 12" (300 mm) and custom shapes are available in a wide variety of colors and textures.

DOWSIL™ 123 Silicone Seal H.C. is a custom extrusion or mold made of higher durometer silicone rubber used in custom applications.

DOWSIL™ 795 Silicone Building Sealant, DOWSIL™ 791 Silicone Weatherproofing Sealant, DOWSIL™ 756 SM Building Sealant or DOWSIL™ 758 Silicone Weather Barrier Sealant may be used as an adhesive with either DOWSIL™ 123 Silicone Seal and DOWSIL™ 123 Silicone Seal H.C.

For more information, see the EIFS Restoration Guide, Form No. 62-510.

DOWSIL™ 756 SM Building Sealant

DOWSIL™ 756 SM Building Sealant is a one-part, medium modulus, neutral-curing silicone sealant designed specifically for weathersealing sensitive substrates where the aesthetic performance of the sealant is important. The sealant is intended for weathersealing skylights, glass facades, porous natural stone, and panel systems where staining and residue rundown streaking must be minimized.

DOWSIL™ 758 Silicone Weather Barrier Sealant

DOWSIL™ 758 Silicone Weather Barrier Sealant is a one-part, neutral-curing silicone sealant designed for adhering to low energy surfaces common in sheet or peel-and-stick weather-resistant barriers. It is available in white.

DOWSIL™ Parking Structure Sealants

DOWSIL™ NS, SL and FC Parking Structure Sealants are low modulus, neutral-curing silicone sealants for use in vertical and horizontal joints in parking structures and stadiums. DOWSIL™ NS Parking Structure Sealant is a one-part, non-sag sealant for vertical or horizontal joints. DOWSIL™ SL Parking Structure Sealant is a one-part, self-leveling sealant for horizontal joints. DOWSIL™ FC Parking Structure Sealant is a two-part, fast-curing sealant for dynamic moving horizontal expansion joints. It is available in gray.

For more information, see the Parking Structure Sealants Installation Guide, Form No. 62-481.

Primers

Dow has a full line of high-performance primers for sealants. Primers are used to enhance adhesion of sealants to specific substrates.

DOWSIL™ 1200 OS Primer

DOWSIL™ 1200 OS Primer is a one-part, low VOC, silane primer for use with DOWSIL™ sealants in many applications to promote adhesion. It is available in clear.

DOWSIL™ Primer-C OS

DOWSIL™ Primer-C OS is a one-part, low VOC, film-forming primer for use with DOWSIL™ sealants on painted and plastic surfaces to promote rapid adhesion. The primer features a unique fluorescent feature where using a UV flashlight (365 nm wavelength) can identify areas where primer was applied.



DOWSIL™ Construction Primer P

DOWSIL™ Construction Primer P is a one-part, film-forming primer for use with DOWSIL™ sealants on porous and cementitious surfaces to promote adhesion. DOWSIL™ Construction Primer P should not be used with DOWSIL™ 790 Silicone Building Sealant, DOWSIL™ Contractors Concrete Sealant or DOWSIL™ Parking Structure Sealants.



Building Sealant Recommendations and Surface Preparation Guide for Weatherseal Applications

Weatherseal

Dow has a full line of high-performance primers for sealants. Primers are used to enhance adhesion.

	DOWSIL™ 756 SM Building Sealant	DOWSIL™ 790 Silicone Building Sealant ¹	DOWSIL™ 791 Silicone Weatherproofing Sealant	DOWSIL™ 795 Silicone Building Sealant
Substrate	Surface Prep ²			
Concrete and Masonry				
Brick	Limited Data/Field Test	No Primer	1200 OS/Primer P	Primer P
Concrete	Field Test	No Primer	1200 OS/Primer P	Primer P
Mortar	Primer P	No Primer	Primer P	Primer P
EIFS³				
All Manufacturers ⁴	Limited Data/Field Test	Limited Data/Field Test	Limited Data/Field Test	Limited Data/Field Test
Stone				
Granite	No Primer	No Primer	Limited Data/Field Test	1200 OS/Primer P
Travertine	Limited Data/Field Test	Limited Data/Field Test	Limited Data/Field Test	Limited Data/Field Test
Marble ⁵	1200 OS/Primer P	Limited Data/Field Test	Limited Data/Field Test	Limited Data/Field Test
Limestone ⁶	1200 OS/Primer P	Limited Data/Field Test	Limited Data/Field Test	Primer P
(Natural Stone) Sandstone ⁶	Limited Data/Field Test	Limited Data/Field Test	Limited Data/Field Test	Primer P
Paints				
Acrylic Latex	Limited Data/Field Test	Limited Data/Field Test	Limited Data/Field Test	Limited Data/Field Test
Duracron	No Primer	Limited Data/Field Test	No Primer	1200 OS/Primer P
Polyester Powder Coating ⁷	Limited Data/Field Test	1200 OS	No Primer	No Primer
Polyurethane	Limited Data/Field Test	Limited Data/Field Test	Limited Data/Field Test	Limited Data/Field Test
Polyvinyl Chloride (PVC)	Limited Data/Field Test	Limited Data/Field Test	Limited Data/Field Test	Limited Data/Field Test
Fluoropolymer				
Kynar	No Primer	Limited Data/Field Test	No Primer	Primer-C OS
Duramar	No Primer	Limited Data/Field Test	No Primer	Primer-C OS
DuramarSunstorm	Limited Data/Field Test	Limited Data/Field Test	No Primer	Primer-C OS
Fluoropon	Limited Data/Field Test	Limited Data/Field Test	Limited Data/Field Test	Primer-C OS
Metals⁸				
Aluminum – Chromate Conversion, Alodine	No Primer	Limited Data/Field Test	No Primer	No Primer
Aluminum – Mill Finish	No Primer	1200 OS	1200 OS	1200 OS
Aluminum – Anodized	No Primer	1200 OS	No Primer	No Primer
Copper	Do Not Use	Do Not Use	No Primer	No Primer
Lead	Limited Data/Field Test	Limited Data/Field Test	Limited Data/Field Test	Limited Data/Field Test
Glass⁹				
Coated Glass ¹⁰	No Primer	1200 OS	No Primer	No Primer
Clear Glass	No Primer	No Primer	No Primer	No Primer
Steel⁸				
Red Lead Primer	Limited Data/Field Test	Limited Data/Field Test	Limited Data/Field Test	Limited Data/Field Test
Weathered	Limited Data/Field Test	Limited Data/Field Test	Limited Data/Field Test	Limited Data/Field Test
Stainless	Limited Data/Field Test	Limited Data/Field Test	1200 OS	1200 OS
Galvanized	No Primer	1200 OS	No Primer	1200 OS/Primer P
Cold Rolled	Limited Data/Field Test	Limited Data/Field Test	Limited Data/Field Test	Limited Data/Field Test
Plastics				
PVC	Limited Data/Field Test	Limited Data/Field Test	1200 OS/Primer P	No Primer
Acrylic	Limited Data/Field Test	Do Not Use	Limited Data/Field Test	Limited Data/Field Test
Polycarbonate	Do Not Use	Do Not Use	Limited Data/Field Test	Limited Data/Field Test

Key: 1200 OS: DOWSIL™ 1200 OS Primer; Primer-C OS: DOWSIL™ Primer-C OS; Primer P: DOWSIL™ Construction Primer P.

Field adhesion tests must be performed at the jobsite to verify sealant adhesion.

¹When using a primer with DOWSIL™ 790 Silicone Building Sealant, apply the primer before installing backer rod and allow the primer to dry. Cold weather and porous surfaces require additional drying time.

²These are typical properties, not to be construed as specifications.

³Do not apply sealant to EIFS finish coat unless approved by EIFS manufacturer.

⁴Cleaning procedures for EIFS systems should be followed (page 61).

⁵The extremely porous nature of some marble, particularly white marble, can contribute to the potential for fluid migration into this substrate. Contact a Dow Building Science Sales or Technical Service Representative when working with marble.

⁶Some limestone and other porous stone substrates contain iron and other impurities that can interact with DOWSIL™ 756 SM Building Sealant, causing discoloration of the sealant and/or substrate. Prior to use, DOWSIL™ 756 SM Building Sealant should be tested for compatibility with these substrates using water immersion.

⁷See Organic Solvent Usage in this Dow Americas Technical Manual (page 58) for comment.

⁸DOWSIL™ Primer-C OS is intended for use on plastics and painted or fluoropolymer coated materials only. It is not intended for use on metals such as galvanized steel, anodized aluminum, etc.

⁹Laminated glass with polyvinyl butyrol (PVB) interlayer may delaminate up to 1/4" at the edges when in contact with a sealant.

¹⁰Do not use DOWSIL™ 790 Silicone Building Sealant on copper sputter coated glass.

This surface preparation guide is intended to aid in proper selection of surface preparation techniques and primers, if necessary, to gain adhesion that meets Dow's requirements. The suggestions in this guide are not blanket-approval recommendations; Dow requires all surface prep recommendations in this guide be verified by field or shop adhesion testing and documented prior to starting the project for each substrate/sealant combination. Failure to verify and document adhesion results may result in adhesion loss that is not covered by the Dow Warranty. Recommendations in this guide have been shown to be the best overall recommendations but do not cover every substrate for each material type or finish listed in this guide. Additionally, substrate manufacturers should be contacted to obtain recommendations for proper cleaning solvents for use with their materials. The entire Weatherproofing section of this manual should be read and understood before proceeding with the evaluations. The following sections must be followed to verify and document adhesion:

- Substrate Cleaning Procedure (page 58)
- "Two Cloth" Cleaning Method (page 59)
- Primer Application Procedure (page 60)
- Field Adhesion Testing Procedure (page 65)
- Field Adhesion Hand Pull Test Criteria (page 66)
- Field/Shop Adhesion Log and Sealant Quality Control Logs (pages 69-71)

Structural

All structural applications must be tested by the Dow test lab for surface preparation recommendations.

Field adhesion tests must be performed at the shop or jobsite to verify sealant adhesion.

Failure to verify and document adhesion results may result in adhesion loss that is not covered by the Dow Warranty. Additionally, substrate manufacturers should be contacted to obtain recommendations for proper cleaning solvents for use with their materials. The entire Silicone Structural Glazing section of this manual should be read and understood before proceeding with the evaluations. The following sections must be followed to verify and document adhesion:

- Substrate Cleaning Procedure (page 25)
- “Two Cloth” Cleaning Method (page 26)
- Primer Application Procedure (page 27)

Silicone Structural Glazing

Introduction

Silicone structural glazing utilizes a high-performance silicone sealant to attach glass, metal or other panel materials, referred to as ‘infill material’ from this point forward. Structural silicone attaches the infill material to a metal frame in lieu of gaskets and mechanical attachments. The windload stresses are transferred through the structural silicone sealant to the structure of the building. The structural silicone sealant must maintain its adhesive and cohesive properties to support the infill material under windload.

Only silicone sealants are suitable for use in structural glazing applications. A considerable amount of time has been spent developing and testing silicone sealants to address the needs of structural glazing applications. Whenever a silicone sealant is used to structurally attach infill materials, a comprehensive quality control procedure must be established to help ensure the smooth, efficient, trouble-free completion of the project.

Specific quality control procedures must be followed on all structural glazing projects to obtain a Dow Structural Warranty.

Structural Joint Design

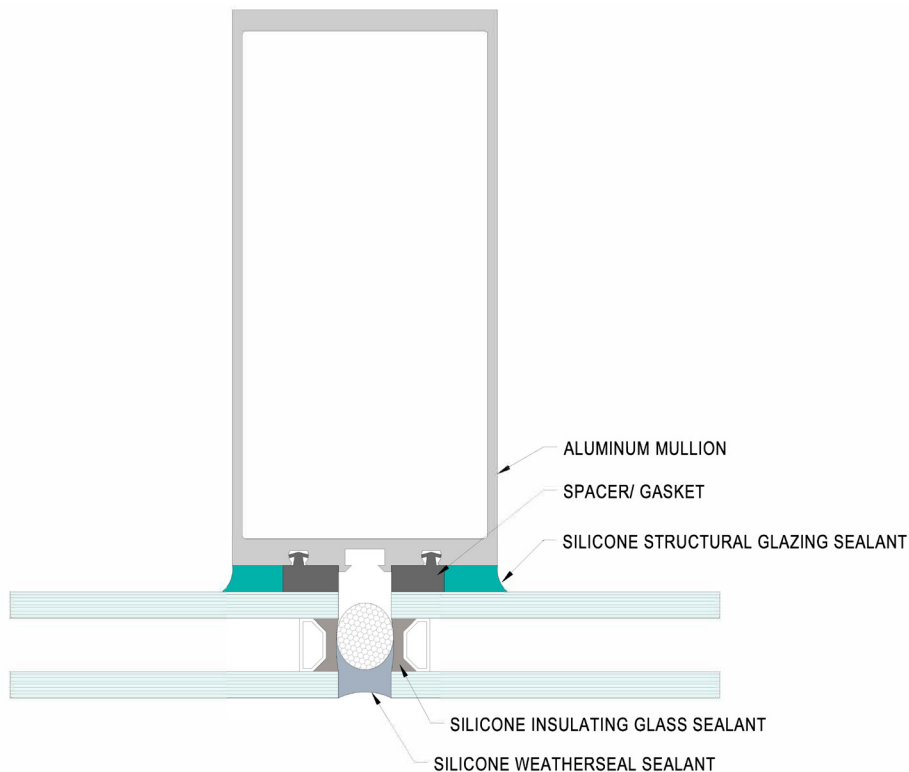

Structural Glazing Design

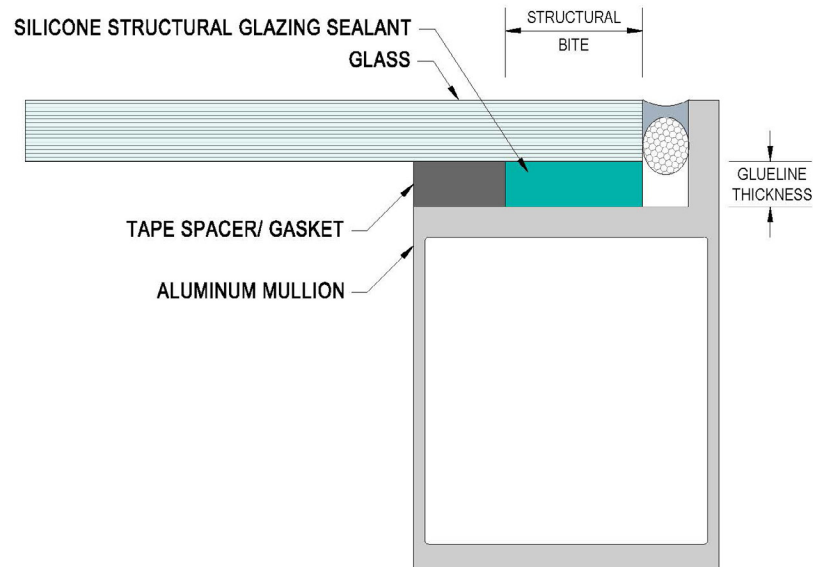

Structural Bite

Structural bite is the minimum width or contact surface of the silicone sealant on both the infill material and the frame. The structural bite requirement is directly proportional to the windload on the building and the size of the infill material. The higher the design windload and the larger the short span dimension of the infill material, the greater the structural bite requirement. The structural bite must be sized appropriately to allow the windload on the infill material to be transferred to the structure. The structural bite for windload (live load) is calculated using the specified windload, infill material dimension and sealant design strength of 20 psi (14,000 kg/m² or 138 kPa).

Structural Bite Calculation

This calculation is used to determine the required structural bite dimension (in imperial units):

$$\text{Bite (inches)} = \frac{0.5 * \text{short span dimension (ft)} * \text{windload (psf)}}{12 \text{ in/ft} * \text{sealant design strength (20 psi)}}$$

$$\text{sealant design strength (14,000 kg/m}^2\text{)}$$

For example, a 1219 mm x 2438 mm lite of glass, exposed to a 290 kg/m² windload, requires a silicone bite of 13 mm. Always round up to the nearest millimeter and never round down.

$$\text{Bite (inches)} = \frac{0.5 * \text{short span dimension (mm)} * \text{windload (kPa)}}{\text{sealant design strength (138 kPa)}}$$

For example, a 1219 mm x 2438 mm lite of glass, exposed to a 3.5 kPa windload, requires a silicone bite of 16 mm. Always round up to the nearest millimeter and never round down.

Note: Infill material rotation under a specified windload can place rotational stresses on a rectangular joint that are not uniform across the silicone bite. It is possible to reduce these stresses by increasing the glueline thickness. Modeling of joint assemblies using finite element analysis can help the designer better understand this potential issue.

Deadload

In unsupported deadload designs, the weight of the infill material places constant load upon the sealant. DOWSIL™ brand structural sealants can support the weight of the infill material when used within the following guidelines:

- For DOWSIL™ 795 Silicone Building Sealant, DOWSIL™ 983 Structural Glazing Sealant, DOWSIL™ 995 Silicone Structural Sealant and DOWSIL™ 121 Structural Glazing Sealant, the allowable deadload design strength is 1 psi or 6.9 kPa.
- The weight of the infill material divided by the total silicone contact area must be evenly distributed and not exceed 1 psi, the deadload design strength of the sealant. Insulating glass unit manufacturers require deadload support for their insulating glass units.

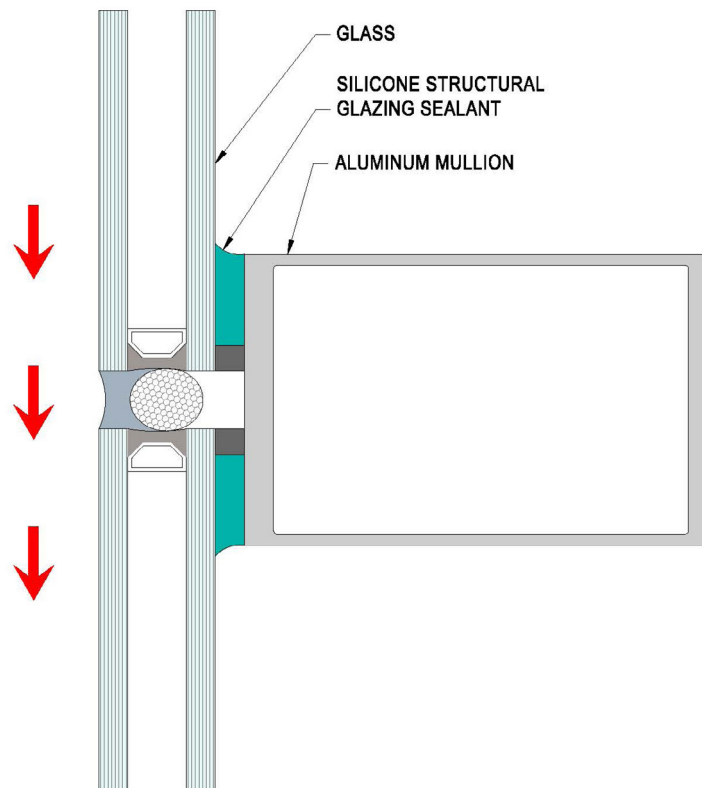

$$\text{Bite} = \frac{\text{weight of glass in lb}}{\text{sealant contact length (inches)} * \text{sealant design strength (1 psi)}}$$

For example, a 4' by 8' lite of monolithic glass at a weight of 3.3 psf will have a weight of 105.6 lb and a glass perimeter of 288". Based on a 1 psi deadload design strength, a bite of 3/8" is required.

This calculation is used to determine the deadload structural bite dimension (in metric units):

$$\text{Deadload Design Strength (SDS) (6.9 kPa)} = \frac{\text{weight of glass (N)}}{\text{sealant contact length (m)} * \text{bite (mm)}}$$

For example, a 1219 mm by 2438 mm lite of monolithic glass at a weight of 145 N/m² will have a weight of 431 N and a glass perimeter of 7.314 meters. Based on 6.9 kPa deadload design strength, a bite of 9 mm is required.

For many slope-glazed systems, the infill material sets on a gasket and the structural joint is installed to the edge of the infill material. The sealant in this application acts as both the structural seal and the weatherseal. Dow permits the use of its sealants in this manner provided that the joint maintains an aspect ratio of 1:1 where the depth of the sealant is equal to or greater than the width of the joint opening. The structural bite in this design is the depth of the joint along the edge of the infill material. The sealant in this design must be structurally attached to a fin that can support the structural load on the infill material. Infill material tolerances must be considered.

This calculation is used to determine the structural bite dimension for outward sloping conditions (in imperial units):

$$\text{Bite (in)} = \frac{0.5 * \text{short span length (ft)} * [\text{windload (psf)} + \text{sine}(\beta) * \text{lite deadload (psf)}]}{12 \text{ in/ft} * \text{sealant design strength (20 psi)}}$$

For outward slope greater than or equal to 15 degrees:

$$\text{Bite (in)} = \frac{0.5 * \text{short span length (ft)} * [\text{windload (psf)} + \text{lite deadload (psf)}]}{12 \text{ in/ft} * \text{sealant design strength (20 psi)}}$$

This calculation is used to determine the structural bite dimension for outward sloping conditions (in metric units):

For outward slope less than 15 degrees:

$$\text{Bite (mm)} = \frac{0.5 * \text{short span length(mm)} * [\text{windload(kPa)} + \text{sine}(\beta) * \text{lite deadload(kPa)}]}{\text{sealant design strength (138 kPa)}}$$

For outward slope greater than or equal to 15 degrees:

$$\text{Bite (in)} = \frac{0.5 * \text{short span length (mm)} * [\text{windload (kPa)} + \text{lite deadload (kPa)}]}{\text{sealant design strength (138 kPa)}}$$

Where (β) is the angle between vertical and the infill material.

Glueline thickness table

Proper glueline thickness facilitates the installation of sealant and allows reduced stress on the structural joint resulting from differential thermal movement. Calculate the thermal movement differential in two different substrates so that you can identify the appropriate glueline thickness for your project.

Calculate BITE, in (mm)	Minimum glueline, in (mm)	Maximum glueline, in (mm)
0.25 (6.4 mm)	0.25 (6.4 mm)	0.25 (6.4 mm)
0.375 (9.6)	0.25 (6.4 mm)	0.375 (9.6)
0.5 (12.7 mm)	0.25 (6.4 mm)	0.5 (12.7 mm)
0.625 (15.9 mm)	0.25 (6.4 mm)	0.5 (12.7 mm)
0.75 (19.1 mm)	0.25 (6.4 mm)	0.5 (12.7 mm)
0.875 (22.3 mm)	0.3 (7.6 mm)	0.5 (12.7 mm)
1 (25.4 mm)	0.34 (8.7 mm)	0.5 (12.7 mm)
1.25 (31.8 mm)	0.42 (10.7 mm)	0.5 (12.7 mm)
1.5 (38.1 mm)	0.5 (12.7 mm)	0.5 (12.7 mm)

Glueline thickness

A minimum glueline of 1/4" (6.4 mm) is required. Increasing the glueline should be considered based on the type of sealant used as well as thermal movement of the infill material. For application purposes, the glueline should be large enough to allow proper fill of the structural joint; joint fill is demonstrated during deglaze activities. For one-part sealants, a 3:1 or less bite-to-glueline ratio should be maintained to support full cure in depth of the joint. One-part sealants cure via reaction from moisture in the air, so deep section joints, 3/4" (19 mm) or greater, may take several months to achieve full cure in depth. The use of two-part sealants allow for greater bite-to-glueline ratios as long as joints are adequately filled and a proper mix occurs to help ensure the desired reaction for property formation. A common application where larger bite-to-glueline ratios occur are in high velocity hurricane zones with excessive windloads.

All structurally glazed infill materials undergo repeated expansion and contraction due to temperature variation. Glueline thickness must be properly designed to accommodate these movements. Thermal movement can be calculated for any infill material or framing member if the length of the material, material type (e.g., glass, aluminum) and their coefficients of thermal expansion (CTE) are known.

Joint movement for a particular infill material can be calculated as follows (in imperial units):

$$\text{Movement (inches)} = \text{panel length (inches)} * \text{CTE (inches/inches/}^{\circ}\text{F)} * \text{temperature change (}^{\circ}\text{F)}$$

For example, a 4' by 8' high lite of glass fixed at the sill with a CTE of 5.1×10^{-6} and a temperature change of 180°F will show movement of 0.088". Aluminum with a CTE of 13.2×10^{-6} will move 0.228". The differential movement between the glass and aluminum will be 0.228" minus 0.088", which is 0.14".

Joint movement for a particular infill material can be calculated as follows (in metric units):

$$\text{Movement (mm)} = \text{panel length (mm)} * \text{CTE (mm/mm/}^{\circ}\text{C)} * \text{temperature change (}^{\circ}\text{C)}$$

For example, a 1219 mm by 2438 mm high lite of glass fixed at the sill with a CTE of 5.1×10^{-6} and a temperature change of 82°C, will show movement of 1.84 mm. Aluminum with a CTE of 23.8×10^{-6} will move 4.76 mm. The differential movement between the glass and aluminum will be 4.76 mm minus 1.84, which is 2.92 mm.

The dimension of glueline required (a) for the differential movement (b) can be calculated using the Pythagorean Theorem. Likewise, the allowable movement (b) for a particular glueline dimension (a) can also be calculated. The new glueline thickness (c) is limited by the movement capability of the sealant in shear in a structural joint configuration.

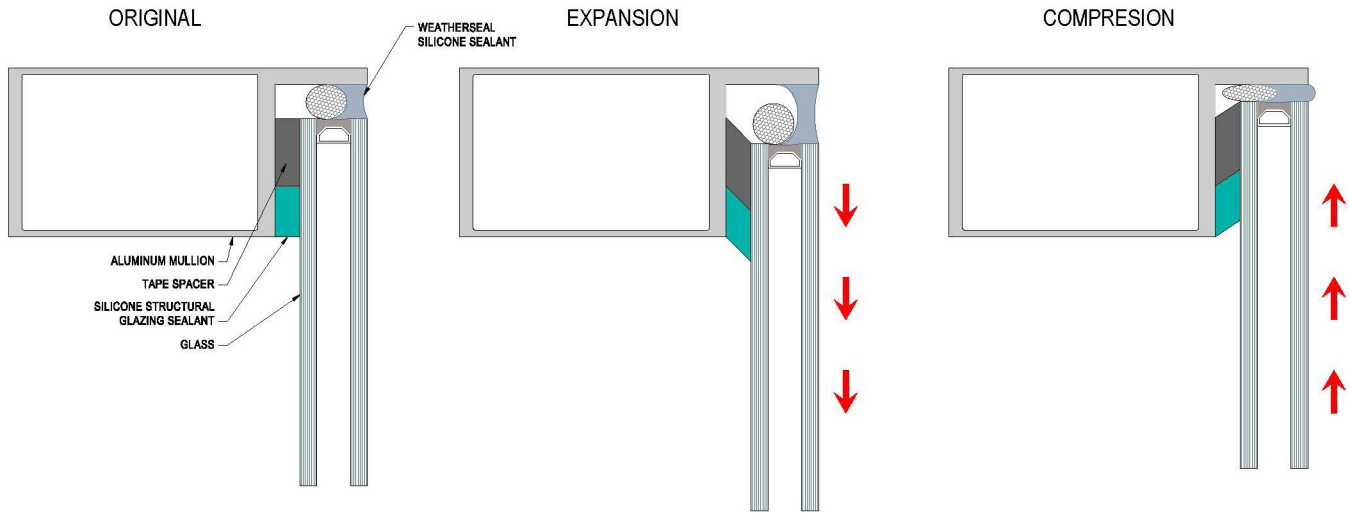

For the above example discussed where differential movement of 0.14" (b) is expected, and the sealant has an original glueline thickness of 0.25" (a), the sealant will elongate to a new glueline thickness of 0.287" (c). Extension of the sealant from 0.25" to 0.287" will be 14.8%.

For DOWSIL™ 995 Silicone Structural Sealant, DOWSIL™ 795 Silicone Building Sealant, DOWSIL™ 983 Structural Glazing Sealant and DOWSIL™ 121 Structural Glazing Sealant, maximum extension from thermal expansion is 15% in any structural silicone joint. The lower allowable movement capability in structural joints is due to the joint design, where the joint width, or glueline, is less than the joint depth, or structural bite.

NOTE: Coefficients of Thermal Expansion values for common building materials are available in the Weatherproofing section of this technical manual.

Direction of infill material movement should also be considered when designing sealant joint dimensions. Thermal movement will occur in one direction in the presence of setting blocks since they prevent any downward movement, but in unsupported systems, the infill material experiences thermal movement in both directions.

Structural Silicone Used in Shear

Structural silicone can be used in shear for live load applications at the same design strength (20 psi, 138 kPa, 14,000 kg/m²) as it is used in tension. This application encompasses Total Vision Systems (fin glazing), some skylight designs and the use of the silicone to reinforce the structure through diaphragm loading.

The modulus of structural silicone in shear is lower than in tension. Recall the Pythagorean Theorem calculation from the Glueline Thickness section of this manual on page 13. Therefore, combinations of shear and tension loading cannot be added without understanding the stress-strain relationship of each joint. Contact a Dow Building Science Technical Service Representative for more information.

Structural Silicone Used in High Design Strength

Dow has a program that enables the use of higher design stresses in structural glazing while using demonstrated successful conventional design methods and Dow's proven and trusted DOWSIL™ sealants. Current DOWSIL™ sealants (995, 983, 121) work effectively in high design strength applications. Dow can approve 0.21 MPa (30 psi) design strength on a per project basis following the minimum 12mm (1/2") bite when designed to 0.21MPa (30 psi). Contact a Dow Building Science Technical Service Representative for more information.

Structural Silicone Used in Seismic Applications

Seismic movement capability of structural sealants primarily results in shear stresses. Based on the stress-strain properties of the structural sealant (DOWSIL™ 995 Silicone Structural Sealant, DOWSIL™ 795 Silicone Building Sealant, DOWSIL™ 983 Structural Glazing Sealant and DOWSIL™ 121 Structural Glazing Sealant), the allowable design limit for seismic movement capability is 25% in any structural silicone joint. This allowable movement is based on a structural sealant with an ultimate strength of at least 50 psi (345 kPa) or a 2.5:1 safety factor, in accordance with ASTM C1184.

For a case study regarding the use of structural sealants in an earthquake, please refer to DOWSIL™ Structural Glazing Sealants Help the Tallest Building in Chile Withstand Glass Breakage During a Magnitude 8.8 Earthquake, Form No. 63-1216.

Additional seismic design information is available in the following ASTM articles:

Broker, K. A., Fisher, S., and Memari, A. M., "Seismic Racking Test Evaluation of Silicone Used in a 4-Sided Structural Sealant Glazed Curtain Wall System," Journal of ASTM International, Vol. 9, No. 3, 2012. pp. 1-22, <https://doi.org/10.1520/JAI104144>. ISSN 1546-962X

Memari, A.M., Fisher, S., Krumenacker, C., Broker, K.A., and Modrich, R.U., "Evaluation of the Structural Sealant Glazing Curtain-Wall System for a Hospital Building," Journal of ASTM International, Vol 9, No. 4, 2012. Paper ID JAI104143

Zarghamee, M. S., Schwartz, T. A., and Gladstone, M., "Seismic Behavior of Structural Silicone Glazing," Science and Technology of Building Seals, Sealants, Glazing and Waterproofing, Vol. 6, ASTM STP 1286, J. C. Myers, ed., American Society for Testing and Materials, Philadelphia, PA, 1996, pp. 46–59.

Splice Joints in Curtainwalls

Splice joints in aluminum curtainwall framing are the highest- and fastest-moving joints in the curtainwall system. Splice joints absorb the daily thermal expansion of 13' to 16' (4 m to 5 m) of aluminum framing exposed to the building's exterior. Field-installed, stick curtainwalls use splice joints to also absorb building deflection, live loads and wind sway.

Avoid splice joints within a structural joint. Placing 13' to 16' (4 m to 5 m) of aluminum frame thermal movement and floor live load deflection into the shearing of a 1/4" (6 mm) wide structural silicone joint will: 1) exceed the design stress of the silicone, causing fatigue; 2) place excessive loading onto the infill material, causing possible failure; and/or 3) cause premature fogging of the insulating glass unit.

If splice joints cannot be avoided within a structural silicone joint, then they should be applied within 1" (25 mm) of the head of the infill material. If silicone failure occurs due to excessive joint movement, the forces on the infill material will be minimized due to the joint placement.

Structural Glazing Guidelines

The following are general guidelines for structural glazing applications. **All exceptions must be handled on a project-specific basis and documented in writing by a Dow Building Science Technical Service Representative.**

- The structural bite must be a minimum of 1/4" (6.4 mm).
- The glueline thickness must be a minimum of 1/4" (6.4 mm).
- The structural bite must be equal to or greater than the glueline thickness.
- For a one-part sealant, the bite-to-glueline ratio must be between 1:1 and 3:1.
- The structural sealant joint must be able to be filled using standard sealant application procedures.
- The joint design must allow the sealant exposure to air so that it can cure and obtain its ultimate physical properties.
- For a two-part sealant, the bite-to-glueline ratio may be greater than 3:1 as long as the joint can be properly filled and the sealant is mixed at the proper ratio during application.
- The structural sealant joint must be fully cured and adhered prior to removing temporary fasteners in the field or moving curtainwall units in the shop.
- Before moving units in shop, fabricators should verify that substantial cure has occurred and adhesion achieved. Evaluation of cure and adhesion can be completed through deglazes or tensile adhesion joints that replicate the joint geometry.

NOTE: Closing off the joint opening with a weatherseal immediately after application of an exterior applied structural joint will drastically slow the cure of the structural sealant.

Substrate Suitability

Dow project services include adhesion and compatibility testing according to ASTM standards. These methods do not encompass any substrate approval; therefore, adhesion or compatibility reports from Dow should not be interpreted as such.

Dow does recognize typical substrates for use in silicone structural glazing based on historical and industry practices, e.g. anodized aluminum. Dow will reject the use of DOWSIL™ brand structural sealants in designs with non-typical substrates without further confirmation of substrate suitability and durability by the substrate supplier.

Where non-typical substrates are specified, a system design professional should be consulted regarding material suitability for structural glazing based on feedback from industry guidelines and substrate manufacturer input. Substrate durability needs to be understood prior to its acceptance and use in structural applications. Dow may require the customer to provide independent confirmation of a substrate's suitability.

Substrates for Adhesion

Metals:

When selecting aluminum substrates for structural glazing, the joint design and adhesion of the structural silicone must be considered. A flat surface with no gasket races, key slots, serrations or other irregularities is required. Some off-the-shelf extrusions may not be suitable for all structural glazing applications. The width of the extrusion must be adequate to achieve the calculated minimum structural bite with a suitable spacer attached.

Extruded mill finish aluminum is not an appropriate surface for structural silicone application. The graphite lubricant used in the extrusion process causes a highly variable surface, which results in unpredictable sealant adhesion. Therefore, aluminum substrates must have a minimum of a chromate conversion coating, like Alodine, for structural glazing applications. Anodizing and thermal set paints, such as fluorocarbon and polyester powder coat, are also suitable aluminum finishes. High-grade stainless steel (316) can also be specified, as verified by past adhesion tests and projects.

Carbon, painted and galvanized steel are generally not appropriate surfaces for structural silicone glazing due to durability concerns when exposed to corrosive agents. Exceptions can be made based on the design. Examples of exceptions include steel components painted with high-performance, industrial-grade coatings or use of structural sealants to adhere galvanized steel backpans in spandrel conditions securing an insulated cavity where panels are not exposed to exterior elements. Exceptions must be approved, in writing, after testing and review by a Dow Building Science Technical Service Representative, the substrate manufacturer and the coating manufacturer.

Masonry:

Masonry and cementitious substrates are typically not appropriate surfaces for structural silicone glazing. The variable substrate alkalinity impacts the adhesion durability and longevity. When structural attachment to masonry is required, install mechanical anchors into the masonry to secure a metal plate, and then bond the structural silicone to the metal. The metal plate must be compatible with masonry and have a high-performance finish.

Insulating Glass (IG)

Insulating glass (IG) units are widely used in structurally glazed facades to improve the thermal performance. Using IG units, architects and specifiers can increase the glass area on a facade without compromising the thermal performance of the building.

When using IG units in structurally glazed facades, specifically developed DOWSIL™ silicone IG sealants should be used. These sealants are ultraviolet light resistant and provide a structural seal bonding the outer glass of the IG unit to the inner glass, providing a structurally bonded system from the outer most piece glass to the building structure. Silicone sealants are the only products that specified in national and international standards for this application. The silicone IG sealant offers structural integrity for the IG unit and firmly holds the two glass elements together, helping to prevent damage to the primary polyisobutylene (PIB) seal, which controls the ingress of moisture into the unit. DOWSIL™ products have a proven track record in this application.

Laminated Glass Considerations

DOWSIL™ silicone sealants have been successfully used in application with laminated glass assemblies using polyvinyl butyral (PVB) as the laminate. There are situations where localized ‘blushing’ and/or localized delamination of the interlayer at the PVB interface, near the sealant contact, may be of aesthetic/visual concern. Shrinkage of PVB laminate at the edge of laminated glass assemblies can be attributed to the loss of unreacted polymers and plasticizers migrating from the PVB and into the sealant. Some PVB interlayers have been seen to show edge delamination without any sealant contact. Based on the degree of the variability surrounding this phenomenon, Dow suggests that a ¼” (6mm) edge effect at the interface of the PVB laminate should be expected when silicone sealants are in direct contact with the PVB interlayer. Extensive testing by PVB manufacturers indicate the presence of edge effects where the PVB laminate was in contact with nearly all sealants used in the study. For further information, contact the laminated glass manufacturer.

If aesthetic issues are critical, then quality parameters and acceptance criteria should be discussed and agreed upon prior to commencement of the project. Options to isolate the sealant from the PVB interlayer have been used on projects by incorporating coatings, tapes and gaskets.

Compatibility should be checked on a job-by-job basis with the actual sheet-form laminate. Compatibility verifies if the laminate causes the sealant to discolor, and if discoloration is observed, it should not be considered an indicator if delamination will occur.

Back-Painted Glass

Back-painted glass is not an appropriate silicone structural glazing substrate because of concerns with substrate durability and coating adhesion to the glass. Adhesion testing completed by Dow only addresses sealant adhesion to its direct substrate and does not encompass adhesion of the coating to the glass.

- Typically, back-painted glass has been used in interior applications with additional mechanical support. Dow can complete adhesion testing to assist in selection of a sealant for non-structural applications.
- Compatibility of the sealant with coating should be addressed by the coating manufacturer. Dow is not responsible for the coating adhesion to the glass and any effect the sealant may have on this adhesion.
- Back-painted glass where the edges have been deleted or not coated along the structural sealant bondline may be tested for structural sealant adhesion and considered a clear glass substrate.
- Glass coatings specifically designed or intended to transfer structural loads (i.e. ceramic frit, enameled, chemically reacted, etc.) should be thoroughly vetted by the coating manufacturer and/or structural engineer for durability in service and impact on glass strength for suitability in application.

Hot-Bent Curved Glass

In conventional structural silicone glazing design, a flat plate of glass tends to deform via the trapezoidal loading theory. For glass plates hot bent into a curved section, the normal loading theory may not apply. The designer must understand that the loading theory may diverge from typical plate analysis. Proper design of hot-bent, curved glass may require additional engineering analysis, such as finite element software, to identify the appropriate distribution of stresses from the curvature. Any analysis should be included with the project drawings submittal as part of the warranty process explained on page 19.

Substrates for Compatibility Testing

Gaskets, setting blocks, spacer materials for structural glazing and accessory materials must be compatible with DOWSIL™ sealants. Dow uses ASTM C 1087-00 (Standard Test Method for Determining Compatibility of Liquid-Applied Sealants with Accessories Used in Structurally Glazed Systems) to test the compatibility of various accessories (setting blocks, gaskets, etc.) with DOWSIL™ silicone sealant. This testing **only assesses the impact that these accessories may have on the performance of the silicone sealant and does not imply compatibility or performance of the other products** (e.g. insulating glass, laminate interlayers, glass coatings, spacer bar materials, etc.) used in the curtainwall or window systems in the presence of the silicone sealant.

Based on historical testing, most 100% silicone setting blocks are compatible for full contact with structural silicones; therefore, 100% silicone setting blocks are the primary recommendation for four-sided SSG applications.

Other materials such as ethylene propylene diene monomer (EPDM), neoprene, Silicone Compatible Rubber (SCR) – an EPDM-based material – and other similar organic materials may cause discoloration of light-colored silicone sealants. In accordance with the criteria in ASTM C1401 Section 34.3, these materials will not be approved for full contact with silicone sealant in structural glazing applications when discoloration is noted.

When using these materials in structural glazing applications, light-colored or gray sealants should not be used. When using gray versions of DOWSIL™ 983 Structural Glazing Sealant, DOWSIL™ 121 Structural Glazing Sealant, DOWSIL™ 982 FS Insulating Glass Sealant and DOWSIL™ 982 Silicone Insulating Glass Sealant, 100% silicone accessory materials are recommended.

When using EPDM, neoprene, SCR and other similar organic materials for weatherseal applications, only dark-colored (black, charcoal or bronze – NOT gray) silicone sealants will be recommended for contact with these materials. If discoloration is severe, even dark-colored silicone sealants may not be approved because of potential long-term adhesion loss. When using insulating glass, the IG manufacturer should be contacted for specific recommendation of setting blocks to help ensure compatibility with the IG unit components (spacer, PIB, glass coatings, etc.).

NOTE: When applying a weatherseal over the silicone setting block, a 1/8" minimum sealant thickness is required.

Project Review Services

Dow Building Science Representatives are available to assist you in selecting the best sealant for your specific application. All silicone structural glazing applications using DOWSIL™ sealants must be reviewed on a project-specific basis by our Dow Building Science Technical Service staff prior to any product selection. The review and testing must be successfully completed, along with factory or site QA documentation, before Dow will issue a warranty. A project submission form is available at dow.com/buildingscience. The following services are offered by Dow.

Product Recommendations

After reviewing project drawings and specifications and having laboratory testing performed, Dow will assist in the selection of the correct DOWSIL™ sealant/primer and/or surface preparation for the specific application.

Print Review

Dow must review all structural silicone details before any approval or acceptance is given. Typical horizontal and vertical details and any non-typical details should be submitted for review. Also, elevations indicating glass dimensions and design windload values for the building should be provided. A few underlying principles are critical to consider in virtually all joint designs using silicone sealants. Dow will review silicone joints for compliance with underlying design principles, provide suggestions or changes, and identify limitations of the designs. The review also allows Dow's Building Science Technical Service Team to confirm all needed components are supplied for complete project review services. These components include bonding substrates, spacers, setting blocks, gaskets, etc.

Adhesion Testing

Dow will evaluate the adhesion of DOWSIL™ sealants to job-site representative materials (e.g. glass, metal, masonry, composites, etc.) using a modified ASTM C794 Standard Test Method for Adhesion-in-Peel of Elastomeric Joint Sealants. All samples submitted for testing should be a minimum of 8" (200 mm) in length. For example, supply one 8" (200 mm) aluminum extrusion sample for each sealant to be tested. For glass, one standard 12" by 12" (300 mm by 300 mm) sample is sufficient. Upon testing completion, Dow will send written product recommendation, surface preparation and primer recommendation (if needed). Adhesion testing takes approximately four weeks from receipt of samples.

Compatibility Testing

Chemically incompatible glazing accessories (gaskets, spacers, setting blocks, etc.) can lead to sealant discoloration and/or loss of sealant adhesion to the substrate. To help ensure a product's suitability, Dow tests the compatibility of job site representative glazing accessories with its silicone sealants using a modified version of ASTM C1087, Standard Test Method for Determining Compatibility of Liquid-Applied Sealants with Accessories Used in Structural Glazing Systems. For each sealant to be tested, supply 4" (100 mm) minimum length of the gasket, spacer or setting block. Written compatibility test results will be communicated. Testing takes approximately four weeks from receipt of samples.

Upon completion of testing, one of three different recommendations will be issued:

1. Not approved for any application - not compatible
2. Approved for contact in structural and weatherseal applications
3. Approved for contact in weatherseal application (dark colors only)

NOTE: in a scenario where dark colors only are recommended, this could be 'block or bronze' or 'black only' based on the available color choices for the DOWSIL™ product tested.

Silicone sealant will yellow when in contact with EPDM, neoprene, bitumen, asphalt and other organic-based membranes, coatings and gaskets; ASTM C1087 confirms the degree of yellowing. Dark-colored sealants typically mask the yellowing. Additional testing may be performed upon request with atypical materials. The section titled "Sealing to Air Barrier Organic Membranes" discusses the application of silicone sealants to membranes.

Some studies have shown the use of DOWSIL™ Construction Primer P to notably reduce or eliminate the sealant discoloration because it is a film-forming barrier. However, this must be verified in field testing on a project-specific basis.

Non-Stain Testing

If a porous substrate, like a natural stone, is being used on a project, Dow can test and evaluate the performance of its sealants to determine if fluid in the sealant has the potential to migrate into the porous substrate and stain. Job site representative samples of the stone, like granite, marble, travertine and limestone, need to be tested using a modified version of ASTM C1248, Standard Test Method for Staining of Porous Substrate by Joint Sealants. For each stone type and sealant to be tested, supply two 1" by 3" (25 mm by 75 mm) samples the thickness of the stone. Larger samples can be cut for testing. Testing takes approximately six weeks from receipt of samples.

Other Test Requirements

Dow can accommodate special, non-standard testing requirements. Please consult your local Dow Representative at the beginning of the project to determine whether Dow is capable of such testing services.

Mock Ups

When fabricating mock ups for structural load testing, the structural sealant must be fully cured and adhered to the substrates prior to running structural load testing. With one-part structural sealants (DOWSIL™ 795 Silicone Building Sealant or DOWSIL™ 995 Silicone Structural Sealant), it is best to leave the weatherseal open until complete cure and adhesion occurs for exterior applied designs. Immediately closing off the joint opening with a weatherseal will drastically slow down the cure of the structural sealant if shot and applied from the exterior.

A one-part sealant can be applied from the interior at the same time the weatherseal is applied from the exterior. This type of application is illustrated in the Joint Composition diagram shown on page 9 in the Structural Joint Design section of this manual. A 12" mini mock-up sample can be made and destructively tested for complete cure and adhesion.

Classification of Silicone Structural Glazing

Two-Sided Structural Glazing

This method uses structural silicone sealant to support the infill material on two sides (either vertical or horizontal edges) and utilizes mechanical support on the other two sides. Two-sided structural glazing can be fabricated in the factory or on site.

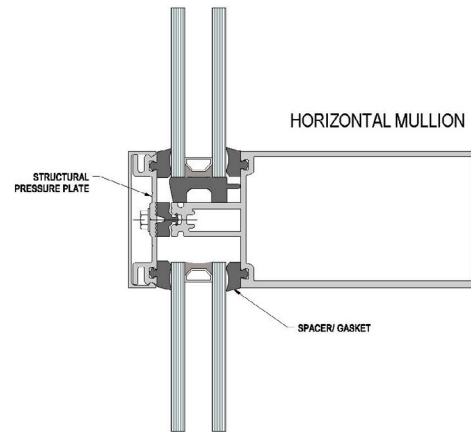
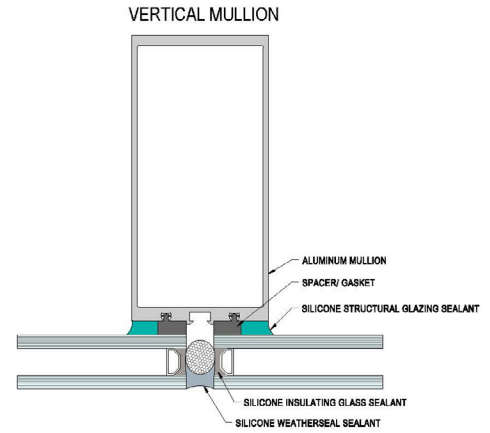
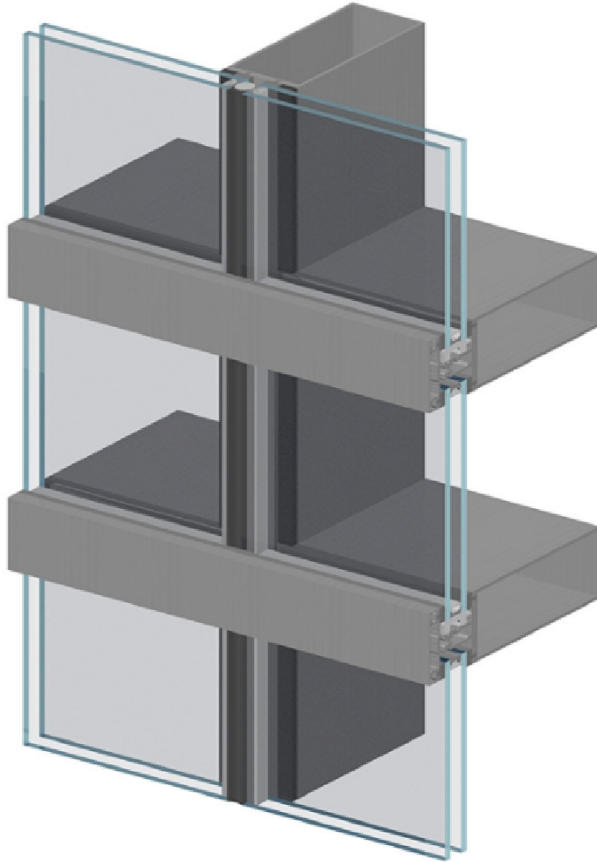

Four-Sided Structural Glazing

Structural silicone is used to bond all four edges of the infill material to the support frame, and the deadload can either be supported mechanically by a fin and setting block or by the structural silicone. It is generally recommended that four-sided structural glazing be performed in a factory.

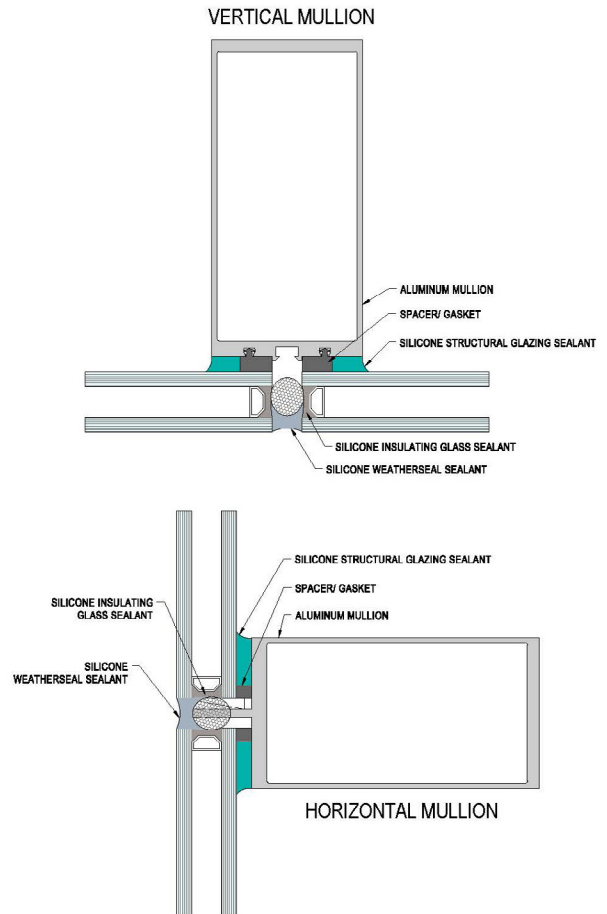
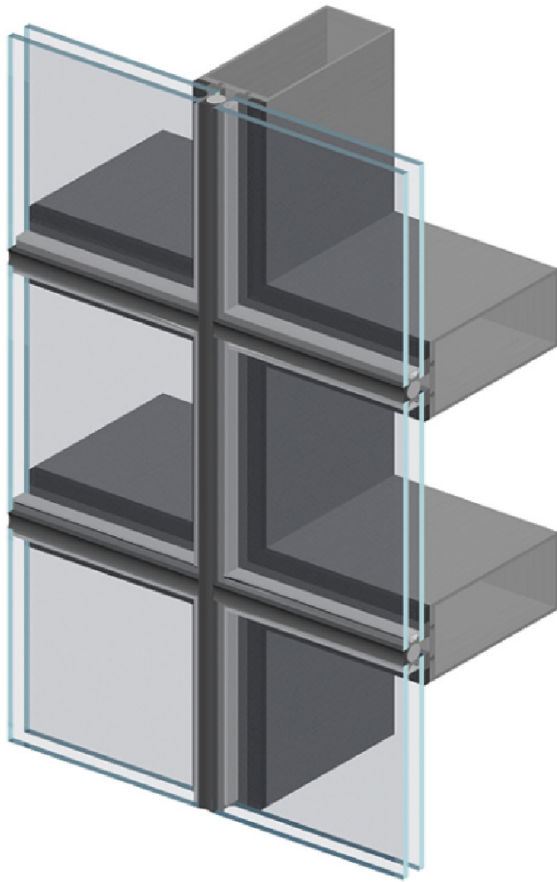

Application Methods for Structural Glazing Systems

Factory (Shop) Glazing

Curtainwalls assembled in a factory environment are assembled in individual units. This system is referred to as unitized curtainwall. Factory construction of the curtainwall units provides a controlled environment where proper surface preparation and sealant application procedures can be maintained and quality control programs can be implemented and documented. After the units are assembled and the sealant has fully cured and developed adhesion, they are shipped to the construction site to be erected onto the building structure.

Site (Field) Glazing

Site glazing is a method that applies structural sealant at the construction site. Infill materials are attached to the mullions and transoms, which are already attached to the building structure. Site glazing is suitable for two-sided structural systems, but it is generally recommended that four-sided systems are factory glazed.

Temporary mechanical fasteners are required to firmly hold and prevent movement of the infill materials until the structural sealant is fully cured and adhered.

NOTE: Special attention to substrate cleaning and sealant application is required under the following conditions:

- Severe wind: Occurrence during application may cause undue stress on the curing structural silicone
- Extremely high or low temperatures: Optimum application temperature range is 10-35°C (50-95°F). For applications below 10°C (50°F), the potential for dew and frost must be considered. For applications in higher temperatures, sealant must not be applied when substrate temperatures are in excess of 50°C (120°F).
- Rain: Remove all moisture from the substrate surface where the sealant joint will be applied. Solvent clean prior to glazing.

Structural Glass Systems (Bolted or Point-Fixed Glazing)

The structural glass or bolted glass system generally has holes drilled at each corner of a glass element. A bolt is used to provide mechanical support for the glass and fixes the glass facade to a metallic structure, which is secured to the main structural member of the building. A high-quality silicone sealant is then used to provide the weatherseal between the glazing elements.

Insulating glass units can also be installed using bolted glass technology. Some systems only drill through the interior lite of an insulating glass unit. In this system, a high-performance silicone insulating glass sealant should be used to produce an edge seal of the insulating glass units to secure the exterior lite to the assembly while maintaining the integrity of the primary PIB seal to protect the interior gas space of the insulating glass. Silicone sealants are used due to their excellent resistance to ultraviolet light, which would degrade organic-based sealants. In this design, the internal glass is bolted back to the main structure, while the external glass is structurally bonded to the inner glass around its perimeter.

Structural glass systems are often referred to as structural glazing, which is often confused with structural silicone glazing. Both techniques use this generic term; therefore, architects and specifiers should be sure which system is being offered.

Total Vision Systems (Fin Glazing)

Total vision or fin glazing is a system used to maximize the area of glass at the front of the building. It reduces the visible mechanical fixings and increases the unobstructed vision area of the facade. Total vision systems are a two-sided structural glazing system in which the glass is normally mechanically fixed at head and sill, and the vertical edges are structurally attached to glass fins or mullions. The glass is bonded to the glass fin using DOWSIL™ structural silicone sealants. The structure is then made watertight using DOWSIL™ weathersealing sealants. This technique is widely used for lobbies, showrooms and racetracks where the unobstructed visibility is an advantage.

Structural Attachment of Non-Glass Materials

Materials other than glass have been successfully attached to buildings with silicone sealants for many years. Examples of these materials include ceramic tiles, plastics, aluminum composite materials and thin stone panels, like granite or marble. In all cases, Dow has performed extensive testing of the specific materials prior to approving the use of its sealant as a structural adhesive. The durability of the non-glass material must be evaluated by the substrate manufacturer to determine its suitability for this application.

Certain materials, such as plastics, may have high coefficients of thermal expansion that may cause undue stress on the structural silicone and/or bowing of the panels. Dow must review all designs, whether glass or non-glass materials, where its sealants are used as structural adhesives.

See also Substrate Suitability on p. 17.

Panel Stiffeners

For aluminum composite materials that are mechanically attached around the perimeter and the sealant is used to attach an aluminum stiffener, Dow permits glueline thickness dimensions of less than 1/4" (6 mm). In this application, there is a negligible amount of differential movement between the two aluminum components, and shear stress on the sealant is minimal. A best practice is to use a spacer material to establish a sealant joint, which can be controlled for width and thickness. Ensure use of suitable sealant for these applications by following the project specification.

Mullionless Corners

When two perpendicular infill panels are joined at a corner only by sealant without attachment to a mullion, termed a mullionless corner, the minimum sealant bite required must be summed for the two infills. In scenarios where the infills are of equivalent dimensions, this would require doubling of the bite to accommodate the transfer of loads.

Protective Glazing Systems

Dow offers structural glazing products that have successfully been used in protective glazing systems designed to meet the demands of missile impact and bomb blast testing. The demands of missile impact and bomb blast testing are great on any sealant. The sealant is only one component of a glazing system that includes the framing system, anchor design, glass type and laminate type. Impact according to standards such as ASTM E1886, Standard Test Method for Performance of Exterior Windows, Curtain Walls, Doors, and Impact Protective Systems Impacted by Missile(s) and Exposed to Cyclic Pressure Differentials, is intended to validate performance of a system subjected to flying debris from hurricanes and windstorms. Assemblies that meet the requirements of this standard must have the glazing stay intact through either a small or large missile impact. The sealant then must "anchor" the laminated glass through repeated wind cycles that mimic a hurricane.

For bomb-blast mitigation glazing, the sealant must also anchor the laminated glass through an air blast explosion. Dow does not approve bomb blast designs because of the intricate interactions between the sealant, glazing and framing. Potential users should either test their system and have it approved, or work with a bomb blast consultant who can review the design and determine the sealant requirements. Dow can provide the consultant with either ASTM D412, Standard Test Methods for Vulcanized Rubber and Thermoplastic Elastomers—Tension, or ASTM C1135, Standard Test Method for Determining Tensile Adhesion Properties of Structural Sealants, sealant strength data for analysis. An extensive test report from the University of Stuttgart testing structural silicones at strain rates up to 5 m/s is available for review.

Both DOWSIL™ 983 Structural Glazing Sealant and DOWSIL™ 995 Silicone Structural Sealant have the high strength and tear propagation properties required to pass either missile impact or bomb blast test requirements. Numerous glazing systems have successfully passed both tests with these two products.

PROTECTIVE GLAZING SYSTEM

A min = C min = 1/4" (6 MM); B = 6 MM

A des = C des = 3/8" TO 1/2" (10 TO 13 MM)

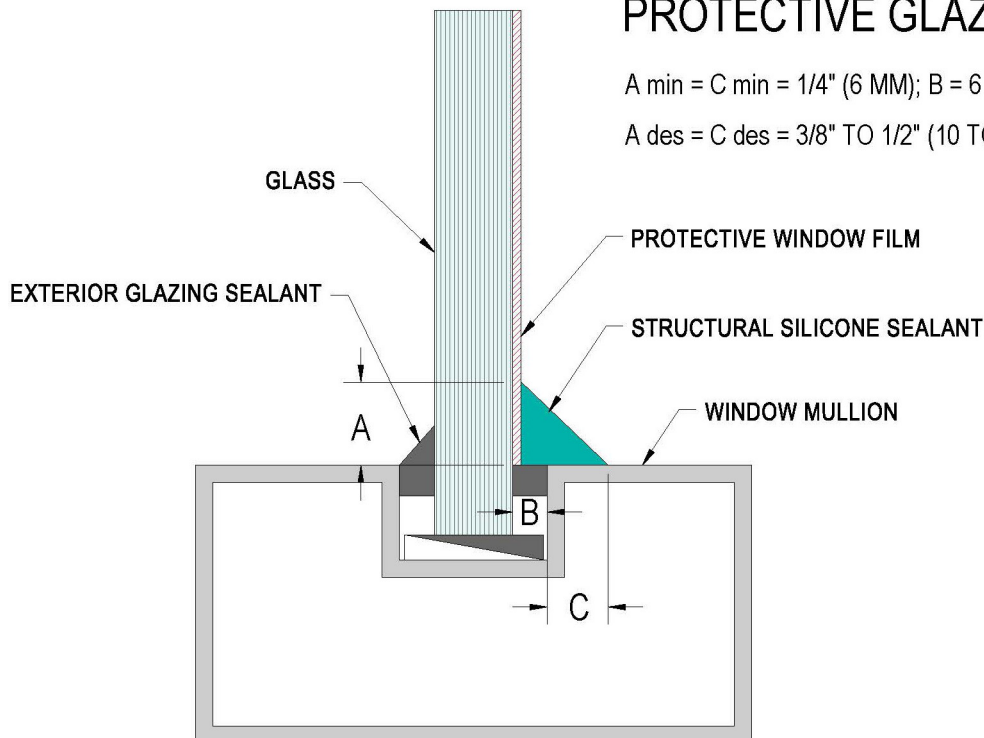

Surface Preparation and Sealant Application

Introduction

The Dow application procedures outlined in this manual describe the general requirements for installing DOWSIL™ Silicone Building Sealants. By following these procedures closely, it will help ensure good sealant performance. To be eligible to receive a Dow warranty, these procedures must be followed. Since DOWSIL™ Silicone Building Sealants are applied in many different environments and situations, these procedures are not intended to be a complete and comprehensive quality assurance program.

The following are the basic steps required for proper structural sealant joint preparation and sealant installation:

1. **Cleaning** – joint surfaces must be clean, dry, dust-free and frost-free
2. **Priming** – if required based on testing, primer must be applied to the cleaned surfaces
3. **Applying Sealant** – sealant is applied by pushing the bead into the structural joint cavity
4. **Tooling Sealant** – sealant is tooled into the structural joint to help ensure it wets out and contacts both sides of the joint and the spacer without any voids in the sealant

Substrate Cleaning Procedure

One of the key requirements of good sealant adhesion is a clean surface. Proper cleaning is accomplished through the use of the two-cloth cleaning method. Always confirm with the supplier of each substrate that the cleaning procedures and solvents are compatible with their material.

Organic Solvent Usage

The proper use of solvents is an important part of the surface preparation requirements for substrates that are to be structurally bonded. Solvents all differ in their effectiveness in removing certain contaminants. Dow will test with the specific solvents selected, and cleaning and priming recommendations will be based on the use of this solvent. Dow recommends caution when using denatured alcohol due to potential contamination from the denaturants.

Please be aware that certain aggressive solvents can adversely affect finishes such as polyester powder-coated aluminum. Therefore, milder solvents such as isopropyl alcohol (IPA) or high quality white spirit (greater than 98% pure) can be used without damaging the substrate surface. Check with the substrate supplier for solvent compatibility with their materials.

Please follow the solvent manufacturer's safe handling recommendations and local, state and national regulations regarding solvent usage.

Non-Porous Substrate – Solvent Considerations

Non-porous surfaces must be cleaned with a solvent before the sealant is applied. The solvent used will depend on the type of dirt or oil to be removed and the substrate to be cleaned. Non-oily dirt and dust can usually be removed with a 50% solution of IPA and water, pure IPA or methylated spirit. Oily dirt or films generally require a degreasing solvent such as xylene or white spirit.

Porous Substrates – Solvent Considerations

Porous stone substrates such as granite or marble might not be sufficiently cleaned by solvent cleaning. Depending on the condition of the surface, porous substrates may require abrasion cleaning, solvent cleaning or both. Laitance and surface dirt must be completely removed.

High pressure water blasting is an effective cleaning method, or a bristle brush with running water may suffice. Porous materials will trap water or solvents after cleaning or priming; hence, water or solvents used for cleaning must be allowed to evaporate completely before sealant is applied.

Two-Cloth Cleaning Method

Clean, soft, absorbent, lint-free cloths, along with the appropriate choice of solvent, must be used. The two-cloth cleaning method consists of a solvent wipe followed by a dry cloth wipe to lift and remove the solvent and contaminants suspended in the solvent. Multiple cleanings may be required to properly clean a substrate.

1. Thoroughly clean all surfaces of loose debris.
2. Pour or dispense an acceptable cleaning-grade solvent onto the cloth. A plastic (solvent-resistant) squeeze bottle works best for organic cleaning solvents. Do not dip the cloth into the container of solvent, as this will contaminate the cleaning agent.
3. Wipe vigorously to remove contaminants. Check the cloth to see if it has picked up contaminants. Rotate the cloth to a clean area and re-wipe until no additional dirt is picked up.
4. Immediately wipe the cleaned area with a separate clean, dry cloth before the solvent has evaporated. This technique will allow dirt and contaminants suspended in the solvent to be lifted and removed with the second dry cloth. Multiple cleanings may be required to adequately clean a substrate.

Organic solvent must be removed with the dry cloth before the solvent evaporates or the cleaning will be less effective. Some surfaces or weather conditions will allow a small amount of residual organic solvent to remain in the top surface layer. If this is the case, the surface must be allowed to dry before installing primer, if needed, and sealant.

Primer Application Procedure

DOWSIL™ primers should be applied in the following manner only to properly cleaned, dry and frost-free surfaces:

1. Apply masking tape to the surfaces next to the joint to keep excess primer and sealant off areas where they are not intended.
2. Pour primer into a small, clean, solvent-resistant container, and replace the cap on the primer can. To minimize deterioration of the primer, do not pour more than a 10-minute supply into the container. Primers need to be stored with the cap tightly closed, as DOWSIL™ primers react quickly when exposed to moisture, reducing their adhesion-promoting capabilities.
3. Depending on the substrate and job conditions, two different methods can be used to apply the primer. Dip a clean, dry, lint-free cloth into the small container of primer, or apply primer from container onto the cloth. Gently wipe a thin film onto the surface. For “hard-to-get-to” areas and rough surfaces, apply the primer in a thin film with a clean brush.
4. Allow the primer to dry until all the solvent evaporates. This typically takes five to 30 minutes, depending upon the temperature and humidity.
5. Inspect the surface for dryness. Caution: Over-priming with DOWSIL™ 1200 OS Primer can cause adhesion loss between the sealant and the primer. If too much primer has been applied, a powdery, chalky, dusty film will form on the surface. Excess primer should be removed by dusting the joint with a clean, dry, lint-free cloth or a non-metallic bristle brush before applying sealant.
6. The surface is now ready for application of the sealant. Sealant must be applied the same day the surfaces are primed. Any surfaces primed but not sealed on the same day must be re-cleaned and re-primed before applying sealant.

Sealant Application Procedure

After cleaning and priming (if required), the sealant may then be gunned into the joint. The spacer may already be in place during the cleaning and priming process or it may need to be installed after the metal substrate has been cleaned and primed. The infill material is typically cleaned before it is put in position. It is critical that the sealant fills the entire joint or cavity and firmly contacts all surfaces intended to receive sealant. If the joint is improperly filled, good adhesion will not be achieved, and sealant performance will be compromised. This is critical since the effectiveness of the silicone in structural applications is largely dependent on the sealant bite (contact area).

Sealant should be applied as follows:

1. To help ensure an aesthetically pleasing job, masking tape should be used to keep excess sealant from contacting adjacent areas where it is not intended.
2. Apply the sealant in a continuous operation using a caulking gun, pump or glazing table. A positive pressure, adequate to fill the entire joint width, should be used. This can be accomplished by pushing the sealant ahead of the application nozzle. Care must be taken to help ensure complete fill of the sealant cavity.
3. Tool the sealant with firm pressure before a skin begins to form (typically 10 minutes). Tooling forces the sealant against the spacer and the joint surfaces. Do not use liquid tooling aids such as water, soap or alcohols. These materials may interfere with sealant cure and adhesion and create aesthetic issues.
4. Remove the masking tape (if used) before the sealant skins over (within about 15 minutes of tooling).

Keyway considerations: It is recommended to always use a flat surface for structural glazing. At times, when additional structural bite is required, it may become necessary to use a keyway as part of the structural bite. If use of a keyway is necessary, the sealant installation into the keyway must be carried out as a separate step. The keyway must be cleaned and primed (if necessary) before the sealant is installed and tooled as its own procedure prior to the remainder of the structural sealant being installed. This is to help ensure full joint fill and adhesion to a flat surface that is contributing to structural bite.

Setting Procedure

Many of the specific requirements of glazing are beyond the scope of this guide. For detailed information, a guide such as the Glazing Association of North America (GANA) Glazing Manual should be consulted. Some general rules to follow when using silicone sealant in glazing applications are as follows:

1. Care must be taken to help ensure that joint surfaces that have been prepared are not contaminated.
2. In some field glazing applications, the silicone may not be applied the same day the glass is set. Joint preparation (cleaning and priming) must be accomplished immediately prior to applying the silicone unless the environment can be proven to not contaminate the cleaned and primed surface or steps are taken to prevent contamination so that glazing can occur within 24 hours after cleaning and priming.
3. Temporary fasteners or clips must be used to retain the structurally glazed lites or panels until the silicone has fully cured. A two-sided adhesive tape, used as the structural spacer, may be considered sufficient temporary support provided the tape manufacturer has approved the use of their product for this application.

Sealant Cure Requirements

In all silicone structural glazing applications, the silicone must be fully cured and adhered before the adhesive is stressed. The exact time can be determined by fabricating several small samples that replicate the joint design of the units. These test specimens should be cured along the curtainwall units. These samples can be cut apart to determine the degree of cure as a function of time. These samples would also be used to check the adhesion of the sealant to the substrates. Full frame deglazes are also used to determine time to full cure and to test adhesion and joint fill (structural bite).

Construction Site (Field) Glazing Considerations

Temporary support of adjoining materials must be used during the cure of the structural silicone sealant. This is to prevent any stress on the sealant prior to full development of sealant adhesion and strength. DOWSIL™ 995 Silicone Structural Sealant and DOWSIL™ 795 Silicone Building Sealant typically require 7–14 days, but depending on joint size, temperature and relative humidity, they can require up to 28 days or more in cold, dry conditions. DOWSIL™ 121 Structural Glazing Sealant typically achieves the necessary strength and adhesion properties in 24 hours, but depending on joint size, temperature and relative humidity, it can require up to 48 hours in colder, drier conditions.

Factory (Shop) Glazing – One-Component Silicone

If DOWSIL™ 995 Silicone Structural Sealant or DOWSIL™ 795 Silicone Building Sealant is used, complete cure of the silicone must be achieved before the units are moved or stressed in any way. This will typically require 7–14 days, but depending on joint size, temperature and relative humidity, they can require up to 28 days or more in cold, dry conditions. The cure time may be shortened in some cases due to warm, humid conditions.

Factory (Shop) Glazing – Two-Component Silicone

DOWSIL™ 983 Structural Glazing Sealant cures in deep section within three hours and generally achieves full adhesion within 24 hours. DOWSIL™ 121 Structural Glazing Sealant generally cures in deep section and achieves adhesion in 24–48 hours. However, time to full cure depends on joint design, substrate type, temperature and humidity. For example, adhesion to a metallic fluorocarbon may take several days to achieve full adhesion, although the time can be shortened by priming the fluorocarbon paint with DOWSIL™ Primer-C OS.

Another consideration is the effects of temperature over the course of a large project. Full adhesion may occur in 24 hours when the project starts in mid-summer, but it may drift to 48 hours as the temperature decreases in winter. The silicone must not be stressed until full adhesion has developed. It is preferable to allow horizontally glazed units to remain on the fabrication tables until full adhesion develops, especially when no two-sided adhesive tape is used. Two-sided adhesive tapes can be used to reduce stressing of the sealant when moving and transferring units during the cure period. Adhesion testing should be carried out to confirm that full adhesion has been achieved. Once full adhesion is verified, units may be moved in a more rigorous manner.

When multiple substrates are glazed on unitized panels, special attention must be given to the support requirements of each substrate.

Replacement and Remedial Glazing

Glass breakage may occur during any phase of construction or long after a building is completed. How a system will be reglazed is an important design consideration.

The specifics will vary from project to project. Always contact your Dow Representative for specific advice. The following are some general guidelines regarding the silicone that should remain common to most all projects.

1. Perform a field adhesion test to confirm the adhesion of the existing silicone to the substrates. If cohesive failure is not observed, contact your Dow Representative immediately. Cohesive failure is defined by the sealant tearing within itself as opposed to releasing at the interface between the sealant and substrate.
2. Deglaze the area. Depending on the joint design, this may require specially designed tools or piano wire to cut behind the silicone.
3. Cut away the silicone, leaving a thin film, approximately 0.02–0.04", (0.5-1 mm) thick of adhesive on the frame. Do not damage the surface finish of the substrate. Alternatively, the sealant can be completely removed, but take care not to damage the substrate finish.
4. Clean the residual sealant with solvent using the two-cloth cleaning technique described previously on p. 26. If fresh sealant will be applied immediately after cutting the cured sealant, then cleaning of the residual cured sealant may not be necessary.
5. Fresh sealant will adhere to cured sealant without primer. Primer may be necessary if sealant has been completely removed.
6. The silicone may absorb some solvent. Allow this solvent to evaporate so the existing cured sealant is completely dry before applying additional sealant.
7. Clean the new glass or panel and set in place. Install temporary fasteners. Mask the joint.
8. Fill the joint with a bead of fresh structural sealant. Refer to the Sealant Application Procedures section on p. 27 of this manual.
9. After the sealant has fully cured, check that full adhesion has been achieved and then remove the temporary fasteners.

NOTE: In some instances, the structural joint cannot be accessed once the glass has been set. In such instances, the sealant can be applied directly to the frame and the glass set in place, compressing the sealant in the joint. The joint must be filled in excess with sealant, and the glass must be set within 10 minutes or before the sealant begins to skin. Under-filled structural joints are workmanship issues. It is the responsibility of the sealant applicator to help ensure proper joint fill. Dow will review and comment upon reglazing procedures.

Replacement Glazing Due to System Failure

If the scope of reglazing involves a major remedial operation, please consult with your Dow Representative as early in the planning process as possible. Remedial glazing utilizing silicone structural sealants most typically occurs when a conventionally glazed building has experienced leakage problems and the entire curtainwall is refaced. In any major remediation situation, it is very important to assess the problem with the system and carefully record dates and locations of specific failures.

Quality Assurance – Structural Applications

Dow performs extensive quality assurance testing in our manufacturing facilities in accordance with rigid ISO 9000 standards. This section is intended to provide the end-user with simple screening tests to verify that the material, as received at the job site, has not been abused or damaged in transit.

One-Part Sealants

The following procedure outlines a series of steps to help ensure that the quality of the DOWSIL™ 995 Silicone Structural Sealant or DOWSIL™ 795 Silicone Building Sealant is adequate for structural sealant applications.

Shelf Life and Storage Conditions

DOWSIL™ 995 Silicone Structural Sealant must be stored at temperatures below 30°C (90°F). The “use by” date is clearly displayed on the product packaging.

DOWSIL™ 795 Silicone Building Sealant must be stored at temperatures below 27°C (80°F). The “use by” date is clearly displayed on the product package.

Skin-Over Time/Elastomeric Test

For one-part sealants, a skin-over time and elastomeric test should be performed once per week and on every new lot of sealant used. The purpose of the test is to check the sealant’s working time and to help ensure the sealant cures fully. Any great variation (excessively long times) in the skin-over time may indicate an out-of-shelf-life sealant.

This test is performed as follows:

1. Spread a bead of sealant into a 0.04” (1 mm) thick film on a sheet of polyethylene.
2. Every few minutes, touch the sealant film lightly with a tool.
3. When the sealant does not adhere to the tool, the sealant has skinned over. Note the time required to reach this point. If a skin has not formed within three hours, do not use this material; contact your Dow Representative.
4. Allow the sealant to cure for 24 hours. After 24 hours, peel the sealant from the polyethylene sheet. Stretch the sealant slowly to see that it has cured. Release the stretch and check to see that it returns to approximately the original length. If the sealant has not cured, contact your Dow Representative.
5. Record the results in the project log book. This testing must be completed and results recorded, retained and available for review upon request. A project quality control log for recording test results is available later in this manual.

Multi-Component Sealants

a. DOWSIL™ 983 Structural Glazing Sealant

Shelf Life and Storage Conditions

DOWSIL™ 983 Silicone Structural Glazing Sealant Catalyst must be stored at temperatures below 26°C (77°F).

DOWSIL™ 983 Structural Glazing Sealant Base must be stored at temperatures below 30°C (90°F) These maximum storage temperatures can also be found on the product labels. The packaging also clearly displays the “use by” date as well as a manufacturing batch number on both the base and catalyst.

Incoming Material Inspection

Prior to using, bring all materials inside and store at shop temperatures. Check for any dents in packaging that may prevent the follower plate from working properly.

DOWSIL™ 983 Structural Glazing Sealant Base, Initial Inspection

Remove the top plastic disc prior to placing underneath the follower plate of the drum pump and bleed off any residual air according to pump instructions. There is no reason to remix the base. An opened drum of base alone will not cure but may become dirty on the top surface.

Application Temperatures: DOWSIL™ 983 Structural Glazing Sealant

DOWSIL™ 983 Structural Glazing Sealant is a two-part structural glazing adhesive intended for in-shop fabrication of structurally glazed curtainwall units and panel systems. The product has an adjustable cure rate to compensate for handling difficulties during gradual cooling or warming trends due to seasonal changes. However, this product should not be used in unheated shops during the winter.

Hence, it is recommended that DOWSIL™ 983 Structural Glazing Sealant be applied between temperatures of 12°C to 35°C (50°F to 95°F). Variable adhesion properties have resulted when the product was applied to curtainwall units in an unheated shop during the winter.

Drums of base and pails of catalyst should be stored indoors to maintain the temperature within the materials. The packaged materials are normally transported in unheated trucks and will be cold in the winter. Once received, the material should be brought indoors and warmed for a few days before using to help maintain consistency of cure and adhesion times. Cold base and cold catalyst will cure slower (even if the shop temperatures are warm), so the material should be allowed to equilibrate for consistent properties. For each 10°C temperature drop, the reaction rate (cure, snap time, adhesion) is decreased by approximately ½. It is not uncommon to see these properties drop during the winter from typical properties seen in the summer. This change in initial properties will not affect the cured performance of the sealant.

Mix Ratio for DOWSIL™ 983 Structural Glazing Sealant

The recommended mix ratio for DOWSIL™ 983 Structural Glazing Sealant is between 8:1 and 10:1 (base to catalyst) by volume. These are standard ratios typically set by pump manufacturers. Based on these volumetric ratios, the weight ratio for DOWSIL™ 983 Structural Glazing Sealant – Black corresponds to 10.3:1 to 13.0:1 (base to catalyst). For DOWSIL™ 983 Structural Glazing Sealant – Gray, using the same volumes, the weight ratio should be 11.0:1 to 13.5:1 (base to catalyst) due to a difference in the specific gravity of the catalysts. This difference is outlined on the DOWSIL™ 983 Structural Glazing Sealant product data sheet.

Dispensing Equipment for DOWSIL™ 983 Structural Glazing Sealant

DOWSIL™ 983 Structural Glazing Sealant requires a plural component, meter-mixing device. Two-part sealant pump manufacturers include but are not limited to Graco, H&G Adhesive Dispensing, Reinhardt Technik GmbH, Nordson Corporation and Erdman Automation Corporation. For further information on the advantages and disadvantages, the reader is encouraged to discuss this with the distribution network of each of these pump manufacturers.

The two-part sealant pumps available all require maintenance and trained operators. It is beyond the scope of Dow as a sealant supplier to provide pump maintenance, spare parts and troubleshooting. The quality control program recommended by Dow, including snap time, butterfly test, shop adhesion testing and deglazing, will show pump problems. Sporadic cure rate, non-uniform color, presence of air and uneven hardness of the finished sealant are issues generally associated with the pump.

A method to evaluate the consistency of mix from the pump is to dispense a winding, snake-like bead of sealant onto a cardboard sheet. Tool the bead to an approximate 1/4" (6 mm) thickness and monitor the cure rate of the sealant. Type A durometer hardness can be used to monitor the rate of sealant cure. If soft spots remain after the bulk of the sealant is cured, there may be a problem with the pump. Please notify your pump manufacturer for assistance.

DOWSIL™ 983 Structural Glazing Sealant will work only when it is metered and mixed without incorporation of air. This requires a properly maintained pump with qualified, trained operators. Critical processing parameters are down pressure on the curing agent and base platens, effective purging during drum or pail exchange, seal integrity, and proper exchanging of a pail or drum before the system runs "dry" or cavitates.

If a pump has been idle between projects, it is suggested that a thorough cleaning and refurbishing of maintenance items be performed. This can be done with the assistance of the pump manufacturer or its distributor.

Dispensing equipment must be used to airlessly meter and mix DOWSIL™ 983 Structural Glazing Sealant. The specific operation and maintenance of the pump are beyond the scope of this document. The applicator must have a start-up, shut-down and maintenance procedure for the pump to properly apply structural glazing adhesives.

When starting the pump, the curing agent line should be opened and material pumped through the line until the sealant exiting the dispensing gun ceases to be white or streaked. Instead, it should be a consistent black or gray color, indicating a mix of the base and curing agent components.

Before shutting down the pump, the static mixer and hoses should be purged with base material and cleaned with an approved cleaning solvent. The amount of wasted material resulting from the start-up and shutdown of the pump varies with the type of pumping equipment used.

As the volume of the hose after the static mixer location decreases, so will the amount of wasted material resulting from start-ups and shutdowns.

Quality control testing to be performed on start-up of the equipment includes the butterfly test and the snap-time test. Descriptions of each follow. Results of these tests must be recorded in a log similar to the example in the Documentation section of this manual on p. 37.

These are guidelines based on Dow's experience and are not meant to supersede any recommendations or documentation from the pump manufacturer.

Butterfly Test



The butterfly test must be performed every time the pump is started up, including start-ups that occur after extended breaks. The purpose of this test is to check for an adequate mix of base and curing agent components.

The test is performed as follows:

1. Fold a piece of plain white paper.
2. Apply a minimum 6" (150 mm) bead length of DOWSIL™ 983 Structural Glazing Sealant to the crease or fold in the paper.
3. Press the paper together, smearing the sealant bead to a thin film.
4. Pull the paper apart and visually inspect the sealant smear formed.
5. Properly mixed material should have no white streaks of unmixed base. If streaks are present, then more material must be pumped through the lines to improve the mixing quality. If the sealant smear is a consistent black color, the sealant is properly mixed and ready for use. Note when using gray catalyst, a consistent gray color without white or lighter gray streaks is desired.
6. If gray or white streaks continue, equipment maintenance may be needed. Cleaning or changing the mixing system, dispensing hose, dispensing gun or ratio system ball check valves can often correct this problem. Consult the equipment manufacturer for maintenance requirements. Application of structural glazing sealant should not proceed with sealant that shows streaking during a butterfly test.

Snap-Time Test

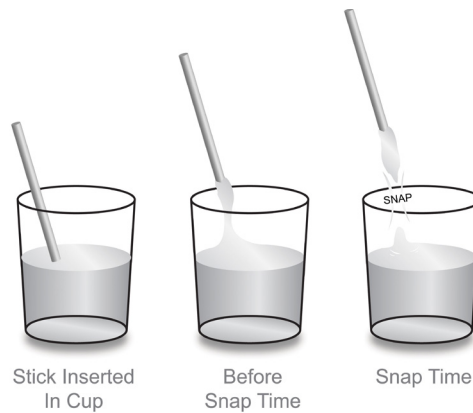

Once full mix of the two-part sealant (as confirmed by the butterfly test) is achieved, a snap-time test should be performed. This test must be performed daily. Snap time can vary from technician to technician. The test relates the base-to-catalyst mix ratio to the cure rate of the sealant and provides an indication of working time and deep section cure. The snap-time test is performed as follows:

1. Fill a small container with DOWSIL™ 983 Structural Glazing Sealant.
2. Place a stick, pencil or spatula into the sealant. (Wooden chopsticks or paint-stirring sticks work well.) Note the time.
3. Every 3 to 5 minutes, pull on the stick. Do not stir the sealant or incorporate air into the mixed sealant.
4. If the sealant does not tear within itself (cohesively) when the stick is pulled out, the sealant has not snapped. The time at which the sealant tears cohesively when the stick is pulled out is termed the “snap time.” Note the snap time in a log.
5. The snap time will vary depending on atmospheric conditions, temperature, humidity and the individual doing the test. A snap time varying more than 25 minutes from what is expected may indicate an equipment or sealant problem. Such problems include plugged hoses, clogged filters, bad check valves or out-of-shelf-life sealant. Consult Dow and the pump manufacturer before continuing to use this material.

Regardless of the results of the snap-time tests, ultimately one should be concerned only if the sealant does not cure. Assuming that the sealant does cure, it is most important that the sealant develops adhesion to the substrate. Snap-time test is an indicator and should be considered as a part of an overall quality assurance program.

Pump Seal Maintenance Check - Snake Test

Worn seals on the volumetric, dual-action catalyst displacement cylinders can cause a variable mix ratio, which can result in an inconsistent cure. This should be checked when a pump is started up for the first time or if soft spots are noticed in the sealant bead. When cylinder seals wear, they can allow an inconsistent amount of catalyst to be mixed into the sealant. This typically occurs as the catalyst volumetric cylinder cycles from one direction to the other and allows back pressure to let catalyst escape from one side. This is a typical maintenance item that should be added to the overall Quality Control program.

1. Turn on the pump and lay a continuous bead back and forth in a “snake-like” pattern on a piece of cardboard. Allow the pump to extrude for 3 to 5 minutes so that 2 complete cycles of the catalyst cylinder are completed.
2. Let the sealant cure for 2 hours.
3. Check the entire bead by pressing your finger into the surface every 2” to 3” ensuring the sealant bead is fully cured along the entire length.

If soft spots are present, it is likely the problem needs to be addressed with a pump technician, who will replace the pump seals. The soft spots will typically occur in a consistent fashion (or specified length) along the extruded bead of sealant.

b. DOWSIL™ 121 Structural Glazing Sealant

Shelf Life and Storage Conditions

DOWSIL™ 121 Structural Glazing Sealant must be stored at temperatures below 30°C (86°F). A “use by” date is clearly displayed in the label of the cartridge.

Application Temperatures: DOWSIL™ 121 Structural Glazing Sealant

DOWSIL™ 121 Structural Glazing Sealant is a two-part structural glazing sealant intended for in-field or in-shop structurally glazed curtainwall units and panel systems.

It is recommended that DOWSIL™ 121 Structural Glazing Sealant be applied between temperatures of -20 to 37°C (-5 to 100°F). The air pressure used to dispense the material should be limited to 90 psi (6 bar) to ensure a good mix and to prevent damage to the sealant cartridge.

Cold kits of material will cure slower even if the shop temperatures are warm. For each 10°C temperature drop, the reaction rate (cure, snap time, adhesion) is decreased by approximately ½. It is not uncommon to see these properties drop during the winter from typical properties seen in the summer. This change in initial properties will not affect the cured performance of the sealant.

Dispensing Equipment for DOWSIL™ 121 Structural Glazing Sealant

DOWSIL™ 121 Structural Glazing Sealant curing agent and base must be thoroughly mixed using an airless mixing system. DOWSIL™ 121 Structural Glazing Sealant is compatible with existing pneumatic dispensing tools which accommodate 2 x 200 mL cartridges. Dow has successfully tested this product with the following pneumatic dispensing tools:

- Sulzer MIXPA DP 400-100-01
- Albion P/N AT400 Standard 400 ml Cartridge Air Gun
- Cox A400HPMR
- Newborn VR400A85

There are battery operated dispensing tools available in the market, Dow has not successfully tested any of them. Please note that use of dispensing equipment of a model or a manufacturer not listed in this document will void any DOWSIL™ product and structural adhesion Limited Warranties. The only exception to this would be if Dow publishes an updated version of this document and/or issues a document indicating the approval of another manufacturer or dispensing equipment model for use with DOWSIL™ 121 Structural Glazing Sealant.

Twelve 18-element, ½-inch diameter static mixers are included in the packaging with the sealant and are required to mix the material. A new static mixer must be used for each cartridge to help ensure proper mixing of the material. Neither hand mixing nor mechanical mixing is satisfactory due to the incorporation of air, resulting in altered physical properties.

1. Attach an air hose to a compressor and to the end of an approved pneumatic sealant tool. The air pressure should not exceed 90 psi or the maximum air pressure listed on the gun, whichever is greater.
2. Ensure the dual pistons are to the back of the gun, so the cartridge can be put in. This can be done using the reverse function on the pneumatic dispensing tool.
3. Remove cap from top of cartridge. Remove the plug on the dispensing end of the cartridge by inserting a flat screwdriver or similar tool into the rectangular slot on the plug. Use the tool to bend the plug 90 degrees as if to make it perpendicular to the cartridge. This movement will release the plug. A second option is to invert the cartridge, firmly tap the top plug on the cartridge on a hard, flat surface, then remove the plug out from the top of the cartridge.
4. Now the cartridge can be inserted. The cartridge should snap into the tool so that the ends of the cartridge are aligned with the dual pistons.

5. Once the cartridge is inserted, ensure that the pistons are set to move in the forward direction. Then, press and hold the trigger until material comes out of BOTH the curing agent and base cartridges. Once both curing agent and base are being extruded from the cartridge, wipe off the excess sealant.
6. Attach a new static mixer. The end of the static mixer can be cut using a sharp knife or scissors to make the tip larger or to slant it at an angle. Do not remove any of the mixing elements in the mixer.
7. With the static mixer screwed on, depress the trigger until the static mixer is completely full and the DOWSIL™ 121 Structural Glazing Sealant can be seen coming out the end of the mixer. This is best done over a waste area. Wipe off the initial material that comes out of the static mixer.
8. The material is now ready to use. For information on installing the sealant into the joint, refer to the Sealant Application Procedure section of this manual on p. 27.
9. Once the cartridge is emptied, reverse the dual plungers. Remove the cartridge and static mixer from the dispensing tool and dispose. The static mixer should not be reused. To use another cartridge of DOWSIL™ 121 Structural Glazing Sealant, repeat steps 3–7.
10. Once you have completed your sealant installation, turn off the air compressor and shut off the air to the gun. Pull the trigger until the air pressure reads zero and then disconnect the air hose from the gun.

Shop/Site Adhesion Testing

Dow requires that adhesion tests be performed on representative production substrates in the shop to verify adhesion of actual production units. Quality control adhesion tests are not a substitute for unit deglazing but only provide an ongoing means to continuously monitor adhesion in a non-destructive manner.

Peel-in-Adhesion Test Procedure

Peel-in-adhesion tests are required to verify sealant adhesion on production materials. Peel-in-adhesion testing should be performed as follows:

1. Clean and prime the surface following the project-specific recommendations.
2. Place a piece of polyethylene sheet or bond breaker tape across the flat test surface.

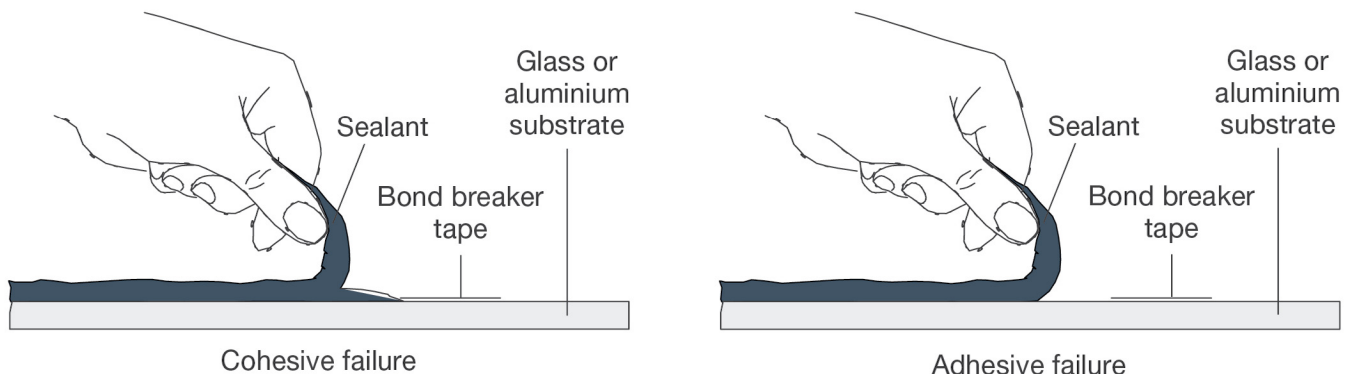

The sealant should be applied to each representative substrate. Sealant samples should be peeled back at the time increment that the units are to be moved. Units may be moved in as little as 4 hours for DOWSIL™ 983 Structural Glazing Sealant or 24 hours for DOWSIL™ 121 Structural Glazing Sealant, but typically cure times are from 1 to 7 days. At the time that curtainwall units may be subjected to stress on the structural silicone, either during transit in the shop or to the jobsite, the sealant must have achieved 100% cohesive failure to each of the substrates that adhesion is required. Only after the sealant has achieved 100% cohesive failure can significant stress be applied to the structural joint. Peel-in-adhesion test results should be correlated with results from deglazing of actual production units.

The tests described above must be performed to verify that adhesion of structural silicone is obtained before curtainwall units are transported to a jobsite and erected on the building. These are daily tests and are intended to verify that all surfaces that require structural adhesion have obtained adhesion before units leave the factory.

Adhesion time of two-component structural sealants can vary with conditions of lower temperature and humidity, and units that do not have full adhesion can lose adhesion during transportation if adhesion is not verified prior to shipment. Curtainwall units should not be subjected to stress unless the sealant has developed full adhesion. Dow should be consulted for recommendations in determining the appropriate handling of structurally glazed curtainwall units.

NOTE: Obtaining Adhesion on Painted Aluminum with DOWSIL™ 983 Structural Glazing Sealant and DOWSIL™ 121 Structural Glazing Sealant

Adhesion development is a key requirement that must be confirmed at each glazing location before subjecting units to considerable movements such as tilting, crating or shipping. However, it may take seven or more days for adhesion to develop between DOWSIL™ 983 Structural Glazing Sealant or DOWSIL™ 121 Structural Glazing Sealant and painted aluminum when either no primer or DOWSIL™ 1200 OS Primer is used. As an alternative, the use of DOWSIL™ Primer-C OS may provide quicker adhesion development on painted substrates compared to no primer or DOWSIL™ 1200 OS Primer.

Deglazing

Deglazing is carried out on infill materials and their frame, which use structural silicone attachment. This method of quality inspection is used to confirm good adhesion and proper fill of the structural joint. Deglazing on silicone structural glazing projects is an excellent quality control procedure that involves completely detaching the infill material from the frame. The structural silicone sealant should be tested for adhesion to both the infill material and the frame. The surface of the infill material and/or frame must not be damaged to obtain the best inspection.

The inspection should include the following and be captured on a Deglaze Inspection Form:

1. Measured size of structural bite (minimum measurement if underfilled)
2. Size of structural glue line
3. Adhesion of silicone sealant to infill material and frame
4. Joint type/condition of sealant applied
5. Appearance of the sealant: uniformity of color, bubbles, etc.

NOTE: When measuring the size of the structural bite during deglazing, if any voids or underfilling occurs, then the measured bite may not meet the minimum bite requirements outlined in the Dow project print review letter and DOWSIL™ Structural Glazing Warranty requirements. The minimum measured bite at any point (on the frame or infill material) governs the measured bite reported on the Deglaze Inspection Form – reporting the average measured bites is not acceptable. Always follow proper application techniques to ensure complete fill is attained to avoid these issues, and the need to reapply the sealant.

Deglazing Frequency

Deglazing may not be required as part of a comprehensive quality control program for structural glazing. Simple processes, such as glazing one to two lites in a storefront application make no practical sense to deglaze unless the design is complicated. For glazing projects with numerous lites, variable geometries or complex design requirements, deglaze operations should be considered part of a comprehensive quality control program and should be agreed upon prior to fabrication between contract glazer, designer, consultant and/or other interested parties. Project documents/specifications should prevail in defining frequency.

Deglaze operations should be conducted to capture the start of fabrication to help ensure quality workmanship with periodic inspection to confirm sustained quality. Dow recommends deglazing according to the following schedule:

1. First deglaze – one unit out of the first ten units manufactured (1/10)
2. Second deglaze – one unit out of next 40 units manufactured (2/50)
3. Third deglaze – one unit out of next 50 units manufactured (3/100)
4. From the fourth deglaze – one unit out of every 100 units manufactured thereafter

NOTE: Current practices in design and fabrication of structurally glazed curtain wall assemblies include the potential for multiple lites or panels to be individually glazed onto one frame. Based on the above description, it is reasonable to define “unit” as one frame consisting of one or more infill materials. It is at the discretion of the fabricator or as a result of contractual obligations to determine the number of infill materials to be removed during the deglaze process. It is reasonable to expect that if only one infill material is removed from a multi-lite frame (“unit”), that lite should be representative of the quality of installation for the remainder of the unit. If there are deficiencies found, then further investigation or deglaze operations should be pursued.

Alternate Quality Control Tests

Quality control tests not identified above may be required or accepted as alternatives to these tests on a job-specific basis. Alternate quality control tests such as tensile adhesion joints have been used successfully to monitor adhesion and cure development of two-component sealants. Water immersion of peel adhesion or tensile adhesion joints may be recommended for a specific project. Unless specifically approved or recommended by the Dow Building Science Technical Service Representative, these tests are not required by Dow.

Documentation – Quality Assurance and Warranty

Suggested logs are provided on the following pages. In the event of a warranty claim or inspection, these must be available from the contractor, subcontractor or owner for review by Dow, the curtainwall consultant and/or the local building official.

It is suggested that these quality assurance logs be kept together with the project file. A hardcover or digital logbook may be preferential to copies of the logs suggested here. A quality assurance professional should be responsible for documenting this data on a job-to-job basis. All curtainwall units must be numbered so the sealant installation dates, sealant lot numbers and quality assurance testing can be obtained from the project log. The position of each panel on the building should be marked on an elevation drawing so that it can be easily traced if required.

Dow will be happy to assist you during the implementation of this quality control program. If you have any questions, contact your local Dow Building Science Sales or Technical Service Representative.

Warranty – Structural Applications

All warranties are dependent on the successful completion of Dow requirements. These requirements include, but are not limited to:

1. The sealant is applied within its stated shelf life;
2. The sealant is applied in strict compliance with Dow's published or electronic application procedures and, where applicable, with any written requirements indicated on the Evaluation Review Summary Letters;
3. The sealant is used with materials that have been evaluated and approved by Dow for compatibility and adhesion, and that the samples of the submitted materials are representative of the materials actually used on the project;
4. The application of the sealant and the joint configuration are completed in accordance with the project prints/specifications; and
5. Adhesion tests are made, documented, retained and submitted to Dow upon written request, to confirm adhesion under site conditions.

At the time of shipment, the DOWSIL™ sealant is warranted that the sealant will meet the Dow sales specification. For further details on the requirements and limitations of this limited warranty, consult the DOWSIL™ product data sheet for the sealant in use.

Dow also offers a project-specific, 20-year performance warranty for sealants used in structural applications. Specific requirements must be met to qualify for this performance warranty.

For details on how to obtain the applicable warranty, please consult your local Dow HPB Sales or Technical Service Representative or authorized building sealant distributor.

Quality assurance requirements for a project-specific, structural performance warranty include, but are not limited to:

Structural Glazing – Construction Site (Field) Applied:

1. Confirmation of Adhesion: Dow Adhesion Letter(s) generated for each substrate that contacts the approved DOWSIL™ Structural Sealant (DOWSIL™ 795 Silicone Building Sealant, DOWSIL™ 995 Silicone Structural Sealant, DOWSIL™ 121 Structural Glazing Sealant or DOWSIL™ 983 Structural Glazing Sealant).
2. Confirmation of Compatibility: Dow Compatibility Letter(s) generated for each accessory material that is used in direct contact with the DOWSIL™ Structural Sealant (DOWSIL™ 795 Silicone Building Sealant, DOWSIL™ 995 Silicone Structural Sealant, DOWSIL™ 121 Structural Glazing Sealant or DOWSIL™ 983 Structural Glazing Sealant).
3. Dow Print Review Approval Letter, which confirms that the documented joints meet Dow performance standards for structural glazing.
4. Field testing documentation log book(s) that show sufficient testing was done. The minimum should be one test per elevation per floor. The contractor should determine other job-specific needs. The contractor should complete and fill out the log to demonstrate that acceptable adhesion was obtained in actual use. This is in addition to the Adhesion Letter noted in #1.
5. The contractor documents and retains all required quality assurance documentation and, upon completion of the project, provides a copy to the owner. This documentation must be retained for this warranty to be valid and will be required should any claims arise in the future. The owner should retain the quality assurance documentation along with the Dow-issued warranty.

Structural Glazing – Factory (Shop) Applied:

1. Confirmation of Adhesion: Dow Adhesion Letter(s) generated for each substrate that contacts the approved DOWSIL™ Structural Sealant (DOWSIL™ 795 Silicone Building Sealant, DOWSIL™ 995 Silicone Structural Sealant, DOWSIL™ 121 Structural Glazing Sealant or DOWSIL™ 983 Structural Glazing Sealant).
2. Confirmation of Compatibility: Dow Compatibility Letter(s) generated for each accessory material that is used in direct contact with the DOWSIL™ Structural Sealant (DOWSIL™ 795 Silicone Building Sealant, DOWSIL™ 995 Silicone Structural Sealant, DOWSIL™ 121 Structural Glazing Sealant or DOWSIL™ 983 Structural Glazing Sealant).
3. Dow Print Review Approval Letter, which confirms that the documented joints meet Dow performance standards for structural glazing.
4. In-shop logs:
 - a. Daily adhesion testing and quality control logs must be completed by the contractor to verify that the units were sufficiently cured and adhered before transported to the site.
 - b. Deglazing documentation log must be completed and filled out by the contractor to demonstrate that acceptable adhesion, void-free fill and sealant bite were obtained on production units per requirements in the log.
5. The contractor documents and retains all required quality assurance documentation and, upon completion of the project, provides a copy to the owner. This documentation must be retained for this warranty to be valid and will be required should any claims arise in the future. The owner must retain the quality assurance documentation along with the Dow-issued warranty.

Dow Project Checklist

The following items must be completed for silicone structural glazing projects. Check off and/or date these items as they are completed. Some items may not apply to all projects. In that case, simply note "NA" (not applicable).

Design Details

- _____ Submit prints to Dow for review
- _____ Include windload and maximum glass size
- _____ Date(s) of Dow print review
- _____ Mock-up drawings/final shop drawings

Adhesion Testing (testing time: 4 weeks, 3 weeks for structural testing and 2 weeks for weatherseal testing)

- _____ Submit job site representative metal (mullion and/or panel)
- _____ Date of Dow adhesion recommendation report
- _____ Submit job site representative glass
- _____ Date of Dow adhesion recommendation report
- _____ Submit job site representative stone
- _____ Date of Dow adhesion recommendation report

Compatibility Testing (testing time: 4 weeks)

- _____ Submit job site representative structural spacer
- _____ Date of Dow compatibility recommendation report
- _____ Submit job site representative setting block
- _____ Date of Dow compatibility recommendation report
- _____ Submit job site representative setting gaskets that will contact structural silicone
- _____ Date of Dow compatibility recommendation report

Quality Assurance

- _____ Perform daily product quality testing and document on log sheet(s)
- _____ Perform daily field/shop adhesion testing and document on log sheet(s)
- _____ Perform deglaze on mock-up and document on log sheet(s)
- _____ Perform deglaze on frame according to schedule

Dow Deglaze Inspection Form

Project Number: _____

Deglaze Date: _____

Project Name: _____

Sealant Applicator: _____

	Frame ID	Panel Size	DOWSIL™ Product	Lot Number	Sealant Application Date	Measured Structural Bite (Frame)	Measured Structural Bite (Glass)	Glue Line
1.								
2.								
3.								

Frame Description: _____

Glass Description: _____

Comments on Adhesion, Joint Fill and Appearance:

1. _____

2. _____

3. _____

Weatherproofing

Introduction

The successful performance of a building exterior is frequently defined by its ability to keep rain and the elements outside, away from the building's occupants. One of the critical links to ensuring a weatherproof building is the joint sealant. Building joints can be sealed effectively by following a few simple guidelines for designing workable joints, selecting the correct sealant, preparing the surface(s) appropriately and performing quality checks to help ensure proper performance.

Joint Movement

Regardless of the size and height of structures, joint movement is inevitable and occurs by various factors like changes in temperature, seismic movement, elastic frame shortening, creep, live loads, concrete shrinkage, moisture-induced movements and design errors. Therefore, each joint should be designed to absorb these movements, using an appropriate sealant.

When movement is caused by temperature change, the degree of joint movement for each material should be considered since all materials have distinct coefficients of linear thermal expansion (CTE). Joint movement caused by thermal expansion can be calculated by the following equation:

$$\text{Movement (Mt)} = \text{CTE} * \text{Temp. Change} * \text{Length of Material}$$

Examples are below:

Max. Temp. (°F)	Min Temp. (°F)	Material Length (inches)	Material	Thermal Coefficient inch/inch/°F	Movement (inches)
160	-20	96	Glass	0.0000051	0.088
100	50	180	Aluminum	0.0000132	0.119
Max. Temp. (°F)	Min Temp. (°F)	Material Length (inches)	Material	Thermal Coefficient inch/inch/°F	Movement (inches)
60	-20	4000	Glass	0.000009	2.88
70	-20	3500	Aluminum	0.0000235	7.40

Average Coefficients of Linear Thermal Expansion for Building Materials - Reference ASTM C1472-06 Standard Guide for Calculating Movement and Other Effects When Establishing Sealant Joint Width¹

Material	mm/mm/°C x 10 ⁻⁶	inch/inch/°F x 10 ⁻⁶
Glass	9.0	5.0
Aluminum	23.2-23.8	12.9-13.2
Granite	5.0-11.0	2.8-6.1
Marble	6.7-22.1	3.7-12.3
Concrete	9.0-12.6	5.0-6.0
Stainless Steel	10.4-17.3	5.8-9.6
Acrylic	74.0	41.0
Polycarbonate	68.4	38.0

¹Typical values not to be construed as specifications.

NOTES:

- The coefficients of expansion for natural materials (brick, stone, etc.) or fabrications of natural materials can be highly variable. If a specific material is specified, then the coefficient for that material should be established and used rather than an average value.
- Moisture-induced movement of brick masonry will cause the brick to swell and reduce joint sizes over the life of the project.

Joint Types

Joints for construction can be put into two classes depending on the degree of movement.

Working Joint (Moving Joint)

Working joints (moving joints) are joints in which the shape and size of the sealant joint changes dramatically when movement occurs. Usually, a working joint occurs on the building envelope when different materials abut each other or joints are designed to allow thermal expansion of materials. Typical examples of working joints include:

- Control Joint
- Expansion Joint
- Lap Joint
- Butt Joint
- Stack Joint

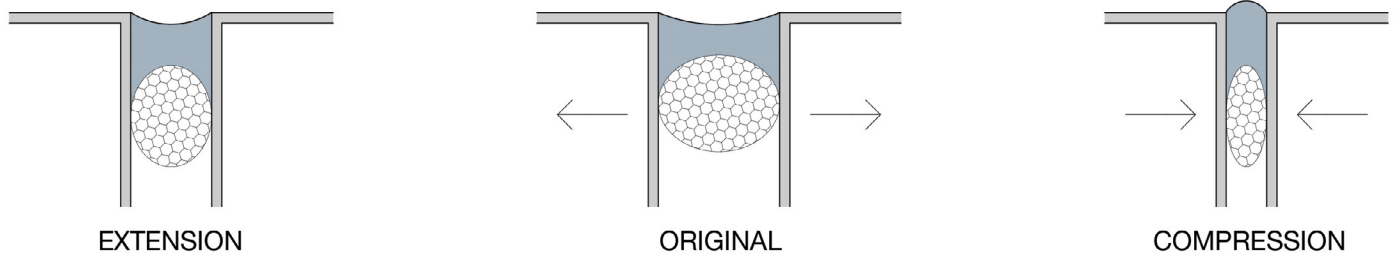

Fixed Joint (Non-moving Joint)

Fixed joints are mechanically fixed to prohibit movement. Movements are generally less than 15% of joint width. These joints are typically designed as air and/or water seals in window systems.

Joint Design

DOWSIL™ sealants have been designed to perform when installed in compliance with accepted weathersealing procedures. Industry guides documenting in detail the procedures for designing weatherseal joints are available in publications such as ASTM C1193 Standard Guide for use of Joint Sealants. Some good examples are found later in this document. **NOTE:** Dow is not responsible for the joint design – that is the task of the engineer of record.

Dow has found that a few underlying principles are critical to consider in virtually all joint designs using silicone sealants. When considering the design of weatherproofing joints, the following basic points must be addressed:

- In all cases, a minimum depth of 1/4" (6 mm) sealant/substrate bond is necessary to help ensure adequate adhesion. **NOTE:** Checking for adhesion and whether priming is needed. In most cases, a minimum width of 1/4" (6 mm) opening is necessary to help ensure that sealant applied from a caulking gun will flow into the sealant joints. **NOTE:** In some cases where the sealant is used simply as a non-moving bedding compound and is applied to one substrate before both substrates are pressed together, thinner joint dimensions are acceptable.
- One-part sealants require atmospheric moisture to fully cure. Therefore, the sealant joint must be designed to ensure that the sealant is not isolated from the air.
- For weatherseal applications where the sealant joint may be covering shims or setting blocks, dimensions may be less than the recommended 1/4" (6 mm) if the application is relatively static, where expected movement is 15% or less. The dimensions should typically not be less than 1/8" (3 mm) to help ensure proper adhesion and sealant property build.

Moving Joint Considerations

When designing moving joints, the following points also need consideration:

- A minimum 1/4" (6 mm) joint width is recommended. Wider joints accommodate more movement than narrow joints.
- Three-sided adhesion limits the amount of movement that a joint can accept without inducing a tear. This can be minimized by the addition of a bond breaker tape or backer rod. With three-sided adhesion, no more than ±15% movement can be accommodated.
- A properly designed moving joint with a 2:1 width to depth ratio will accommodate more movement than a thick joint (i.e., 1.5:1 or 1:1 ratio). Sealants are designed to offer optimum performance when the joints are shaped like an hourglass and use the 2:1 width to depth ratio.
- As the sealant joint width becomes larger than 1" (25 mm), the depth should be held at approximately 3/8" to 1/2" (9 mm to 12 mm). There is no need for greater sealant depth with a silicone sealant. This may mean that the width to depth ratio will be greater than 2:1 (i.e. 3:1).
- Joint widths up to 4" (100 mm) can be accommodated with silicone sealants. Wide joints may require additional care and attention to detail to provide an aesthetically pleasing finish. Wider joints may be better accommodated by DOWSIL™ 123 Silicone Seal. For large joints that will be hidden by cladding such as the perimeter of curtainwall systems, DOWSIL™ Silicone Transition Strip may be an option. Wide joints intended for seismic performance can also be designed using DOWSIL™ 123 Silicone Seal.
- For further information, see [Construction Calculators](#) under the Highlights section of the Dow Construction Website.

$$\text{Minimum Joint Width} = \frac{100}{X} * (Mt + M1) + T$$

X = Sealant movement capacity (%)

Mt = Movement due to thermal expansion

M1 = Movement due to live loading

T = Construction tolerance

For example:

A horizontal joint between an aluminum curtainwall and a concrete panel with a combined thermal movement of 5/16" (8 mm), live load movement of 1/4" (6 mm), construction tolerance of 1/4" (6 mm) and 25% movement capacity sealant would be:

$$\text{Width} = 100/25 * (5/16" + 1/4") + 1/4"$$

$$\text{Width} = 2-1/2"$$

$$\text{Width} = 100/25 * (7.94 + 6.35) + 6.35$$

$$\text{Width} = 63.51 \text{ mm}$$

Joint Movement in Shear

When joints move in shear, greater joint movement can be accommodated since actual movement on the sealant is less. The joint width required (a) for joint movement (b), or the allowable movement (b) for a particular joint width dimension (a), can be calculated using the Pythagorean Theorem. The new joint width after movement (c) is limited by the movement capability of the sealant in shear in a weatherseal joint configuration. The calculation is as follows:

Weatherseal in Shear

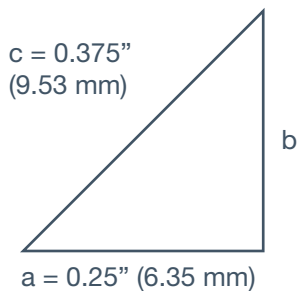
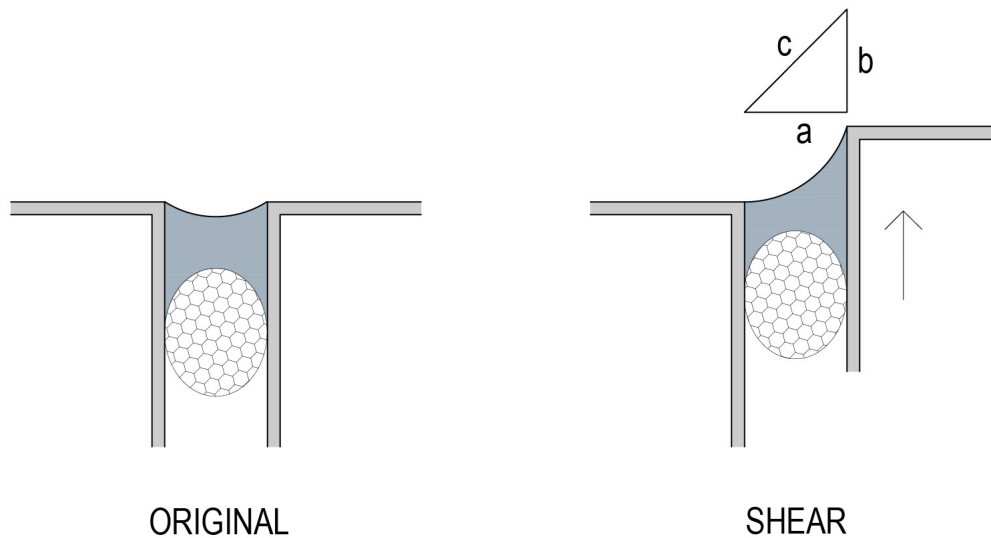

$$a^2 + b^2 = c^2$$

where a = original glueline

b = max. shear joint movement

c = new glueline after joint movement

Original Joint Width (inches)	Sealant Movement Capability Expansion	Max. Shear Joint Movement (inches)
0.25	50	0.280
Original Joint Width (mm)	Sealant Movement Capability Expansion	Max. Shear Joint Movement (mm)
6.35	50	7.11

For example:

English units	0.SI units
$c = a + a * (\text{movement capability in expansion})$ $c = 0.25'' + 0.25'' * (50\%)$ $c = 0.375''$ $a^2 + b^2 = c^2$ $(0.25'')^2 + b^2 = (0.375'')^2$ $b^2 = 0.078 \text{ in}^2$ $b = 0.280''$	$c = a + a * (\text{movement capability in expansion})$ $c = 6.35 \text{ mm} + 6.35 \text{ mm} * (50\%)$ $c = 9.53 \text{ mm}$ $a^2 + b^2 = c^2$ $(6.35 \text{ mm})^2 + b^2 = (9.53 \text{ mm})^2$ $b^2 = 50.50 \text{ mm}^2$ $b = 7.11 \text{ mm}$

Movement During Cure

One-part DOWSIL™ sealants cure by reacting with atmospheric moisture. Sealants will initially form a tack free skin within several minutes or hours. Full depth of cure can take several weeks as part of the cure cycle depending on size of joint and environmental conditions with adhesion fully forming towards the end. Joint movement during cure can cause unsightly aesthetics due to joint deformation, e.g., wrinkling. Full adhesive characteristics of the sealant are obtained after the sealant has cured. If the joint sees excessive movement before the sealant has fully cured, premature adhesion loss may occur. Adhesion loss due to movement during cure can be minimized by using a primer. Primers can shorten the time to achieve full adhesion. Wrinkling can be minimized by following these suggestions:

- Use open-cell polyurethane backer rod
- Seal when the joint surface is cool and will experience minimum temperature changes, typically in the late afternoon or early evening.
- Place no more than 1/4" (6 mm) of sealant over the backer rod at the center

These suggestions should help minimize wrinkling but may not eliminate it, as most sealants are prone to this aesthetic issue. This issue is not known to affect the long-term performance of the joint and will not void any DOWSIL™ weatherseal warranty.

Backer Materials

A backer rod is the typical backer material for most weatherseal joints. The role of a backer rod is to allow a sealant to be installed and tooled to a proper joint profile. Once the sealant cures, the backer material must not restrict the movement of the sealant or cause three-sided adhesion. To provide sufficient backpressure during sealant installation, the backer rod should be sized ~25% larger than the joint opening. Sizing differs among backer rod types; refer to the manufacturer's recommendations. Generally, three common backer rod types can be used with DOWSIL™ sealants:

- Open-cell polyurethane
- Closed-cell polyethylene
- Non-gassing polyolefin

Each backer rod type has demonstrated successful performance with DOWSIL™ sealants.

When selecting a backer rod, consider the following:

- Open-cell polyurethane backer rod allows the sealant to cure through the backer rod, which is beneficial when fast sealant cure is desired. Open-cell polyurethane backer rod can absorb water, which may have a detrimental effect in certain joint types.
- Closed-cell polyethylene backer rod may outgas if punctured during installation, requiring it to be left for 20 minutes before application of the sealant.
- Other back-up materials such as expanding foam tapes or glazing gaskets should be reviewed or tested for compatibility prior to use.
- When a backer rod cannot be positioned in a joint opening, a Teflon® or polyethylene tape should be used to help to prevent three-sided adhesion.

Dow makes the following exceptions when selecting backer rod types:

- For double weatherseal joints, open-cell polyurethane backer rod must be used unless the interior seal is allowed 7 days' cure before installing the exterior seal.
- Specific to DOWSIL™ 790 Silicone Building Sealant, open-cell polyurethane backer rod is recommended against non-permeable surfaces such as painted or metal surfaces to promote cure from both sides of the joint.
- Because Exterior Insulation and Finish Systems (EIFS) manufacturers do not permit the use of open-cell polyurethane backer rod with their systems, use a DOWSIL™ sealant that is recommended for use with EIFS and closed-cell backer rod.
- In some horizontal joints where water can collect, open-cell polyurethane backer rod should not be used.

Hydrophobic Effects

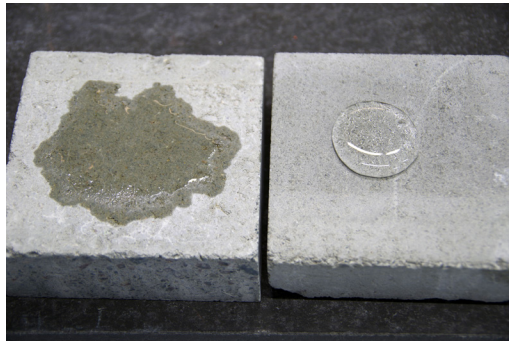

Silicone sealants cure with moisture in the atmosphere reacting with a functional silane in the presence of a catalyst and functional silicone polymers. The silane crosslinkers are of the same chemical structure as the materials used to waterproof concrete structures such as parking garages and bridge decks. Silane crosslinkers are used in all silicone sealants and the silicon-modified organic materials (polyethers and acrylics) that are used as sealants in the construction industry.

As a silicone sealant is applied into a joint, there is the potential for the excess crosslinkers to migrate into the porous material and crosslink into a hydrophobic resin beneath the surface. On occasion, this hydrophobic resin will not allow water to penetrate into the stone adjacent to the joint and may cause a dry area to appear outlining joint in a rainstorm. While this phenomenon does not always occur, it can be attributed to the inherent nature of the necessary silane crosslinkers in the sealant formulation. It cannot be guaranteed that this phenomenon will never occur with a specific porous substrate. However, there are steps that can be taken to minimize the potential occurrence.

Minimizing Hydrophobing

- When priming, use a resin-based primer, like DOWSIL™ Construction Primer P, as opposed to a silane primer, like DOWSIL™ 1200 OS Primer.
- Avoid over-application of any primer, silane or resin onto the visible surface of the facade.
- Use an open-cell polyurethane backer rod as opposed to a polyethylene or polyolefin backer rod. This will allow a curing of the excess crosslinker to occur along the backside of the joint and minimize a catalyst/crosslinker mixture migrating into the stone.
- Design sealant joints to have the optimal amount of sealant to manage the amount of potential exposure to excess cross-linker material.

EIFS Considerations for Design and Specification

Exterior Insulation and Finish Systems (EIFS) offer unique challenges due to its composition. DOWSIL™ silicone sealants have a demonstrated history of success when used with EIFS and offer distinct benefits over organic sealants when used with EIFS.

Consider the following benefits offered by DOWSIL™ sealants:

- DOWSIL™ 790 Silicone Building Sealant, the preferred sealant for EIFS expansion joints, has exceptional ultra-low modulus properties, movement capability of +100/-50% and a proven 40+ year performance on buildings.
- DOWSIL™ one-component silicone sealants require no special mixing, unlike multi-component polyurethane sealants.
- DOWSIL™ sealants have been tested and recommended by most major EIFS manufacturers for use with their systems.
- DOWSIL™ silicone sealants are UV stable and are virtually unaffected by outdoor weathering. Silicone sealants have a life expectancy of greater than 20 years, compared to 5 to 10 years of life expectancy for many organic polyurethane sealants.
- An inorganic silicone sealant maintains its low modulus when cold, whereas an organic polyurethane sealant can get 2 to 3 times stiffer in cold temperatures. Low modulus silicone sealants put less stress on softer EIFS coatings when a joint opens up during cold temperatures.

Refer to EIFS Application Procedures on p. 61.

For EIFS restoration, please refer to the EIFS Restoration Guide, Form No. 62-510.

Weatherseal Design Examples

Examples of a variety of weatherseal joints follow with a review of joint type for key points and concerns.

Minimizing Hydrophobing

Good Joint Design

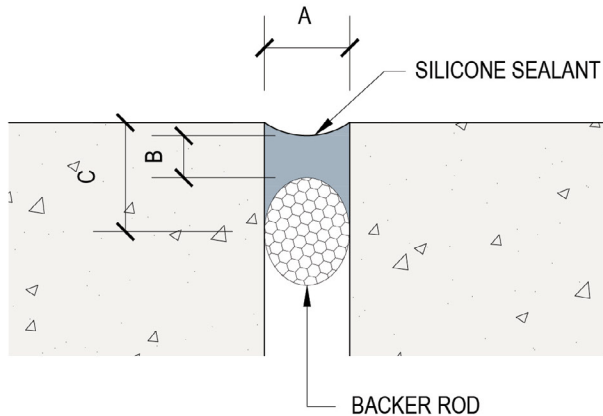

A:B RATIO \geq 2:1

Poor Joint Design

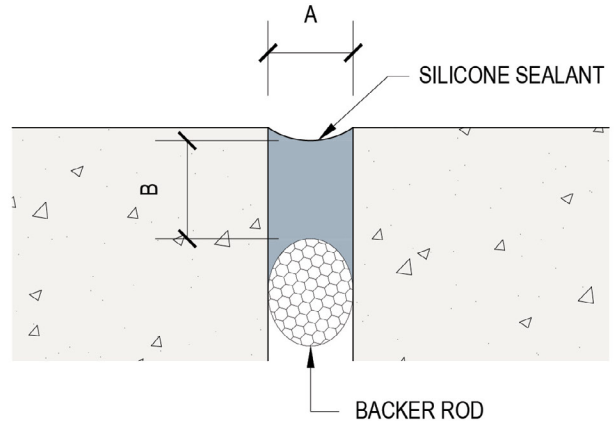

A:B RATIO $<$ 2:1

Good Joint Design – Key Points:

1. Dimension A (joint width) must be at least 1/4" (6 mm).
2. Dimension B (joint thickness) must be at least 1/8" (3 mm).
3. Dimension C (joint depth) must be at least 1/4" (6 mm).
4. Ratio of A:B should be 2:1 minimum.
5. Joint surface tooled.
6. Dimension B suggested Maximum = 1/2" (13 mm).
7. Dimension A Maximum = 4" (102 mm). Joints wider than 2" (51 mm) may slump slightly; therefore, double application techniques of the sealant may be required.

Poor Joint Design – Concerns:

1. A deep sealant joint will not have the same movement capability as a properly designed joint.
2. Slow cure due to excessive sealant depth.

Moving Corner Joints

Good Joint Design

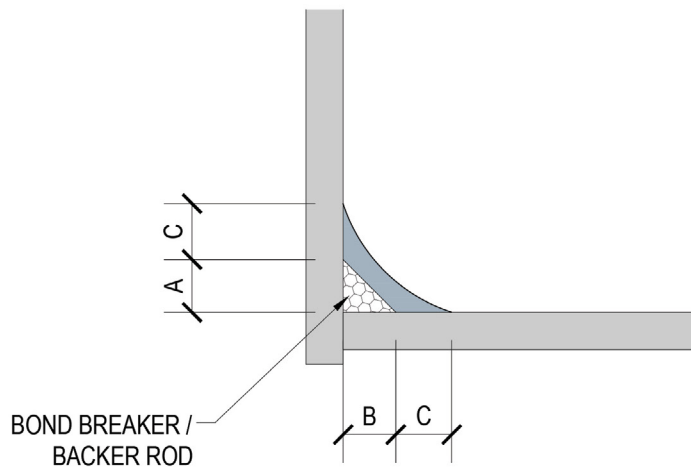

Poor Joint Design

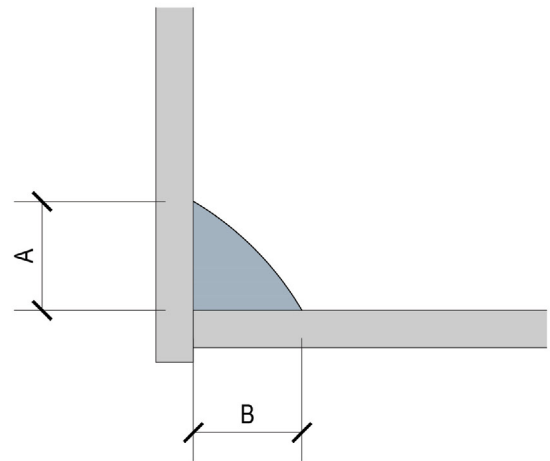

Good Joint Design – Key Points:

1. Dimension A and B must be at least 1/4" (6 mm).
2. A bond breaker tape or backer rod must be present if joint movement is anticipated.
3. Joint must be tooled flat or slightly concave.
4. Dimension C must be at least 1/4" (6 mm).

Poor Joint Design – Concerns:

1. Dimension A or B less than 1/4" (6 mm).
2. Joint not properly tooled.
3. No bond breaker material; therefore, the joint will not accept movement.

Remedial Joints

Good Joint Design

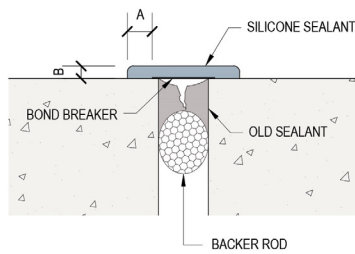

Poor Joint Design

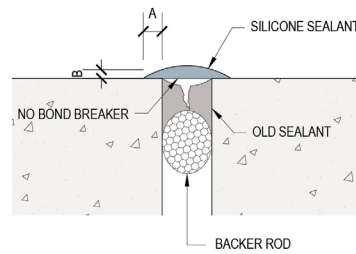

Good Joint Design

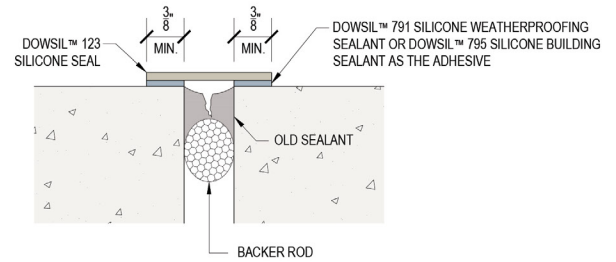

Good Joint Design – Key Points:

1. Dimension A (sealant contact width) must be at least 1/4" (6 mm).
2. Dimension B (sealant thickness) must be at least 1/8" (3 mm).
3. Bond breaker tape must be used to isolate fresh sealant from failed organic weatherseal and to allow joint movement.
4. If existing sealant has not lost adhesion to the substrate, disengage it before applying silicone sealant.

Poor Joint Design – Concerns:

1. Dimension A less than 1/4" (6 mm) increases difficulty in obtaining adhesion and increases the likelihood for voids.
2. Dimension B less than 1/8" (3 mm) increases the likelihood of pinholes or voids in tooling; poor cohesive integrity.
3. No bond breaker material; therefore, the joint will not accept movement.

Key Points:

1. Joint is very difficult to clean.
2. Bond breaker hard to position/size correctly.
3. Movement during cure can cause joint failure.

Cap Bead Glazing Joints

Good Joint Design

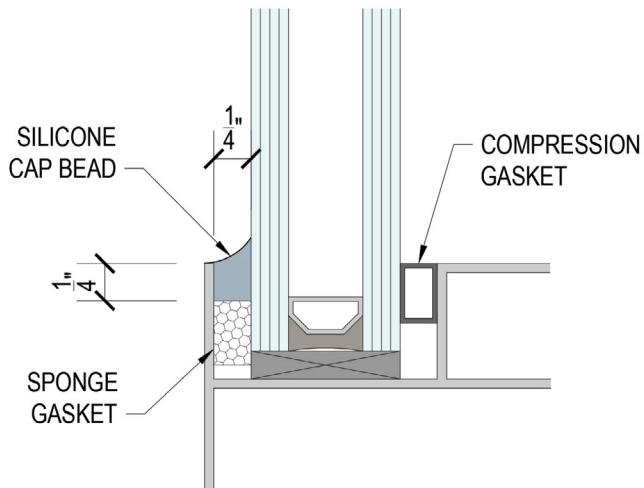

Poor Joint Design

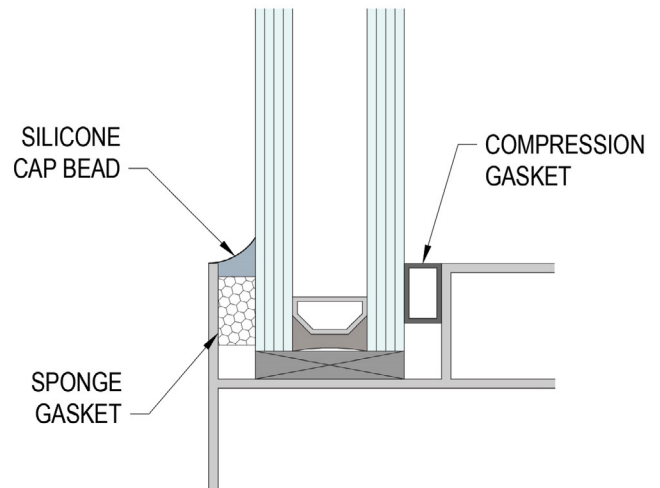

Good Joint Design – Key Points:

1. Sealant contact on glass and metal is at minimum 1/4" (6 mm).
2. Silicone is compatible with gasket.
3. Dark-colored sealant masks possible discoloration from the gasket.

Poor Joint Design – Concerns:

1. Inadequate contact between sealant and external metal.
2. Gray sealant is prone to discoloration.

Dual-Seal Moving Weatherseal

Good Joint Design

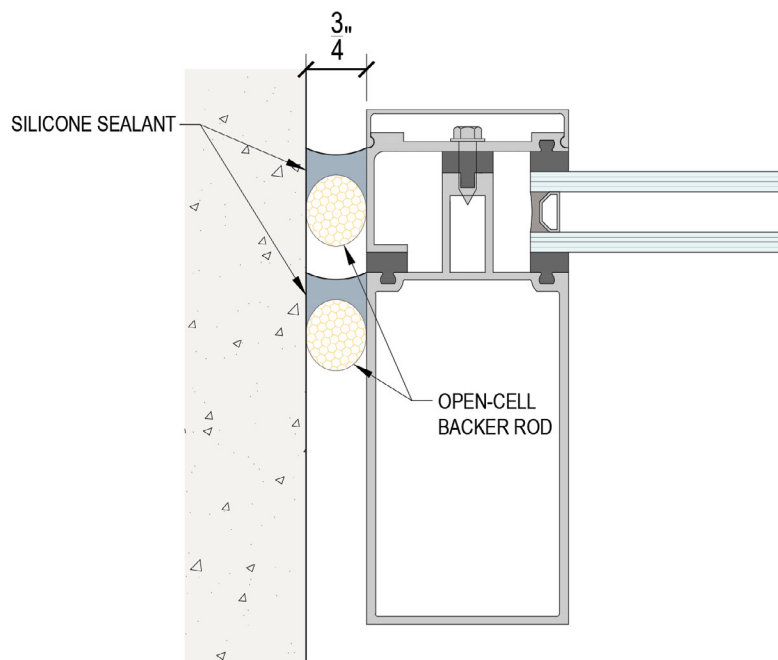

Poor Joint Design

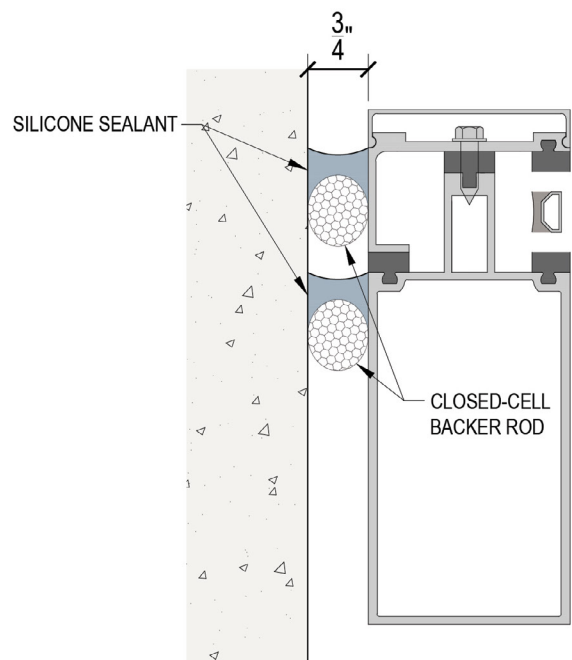

Good Joint Design – Key Points:

1. Both weatherseals comply with the requirements for conventional moving weatherseals (addressed previously).
2. Open-cell backer rod is used to help ensure full cure of the back weatherseal.
3. If closed-cell backer rod is used, the back weatherseal must be fully cured prior to the installation of the exterior seal.
4. Dimension A is at least 3/4" (19 mm) wide to assist application of the rear sealant joint.

Poor Joint Design – Concerns:

1. If both joints are sealed at or near the same time, the closed-cell backer rod will prevent moisture from reaching the rear sealant joint, and the sealant will not cure.
2. Dimension A is less than 3/4" (19 mm), making application of rear joint difficult.
3. Exterior joint seal to aesthetic snap-on cap.

Window Perimeter Joints: Insufficient Aluminum Extrusion

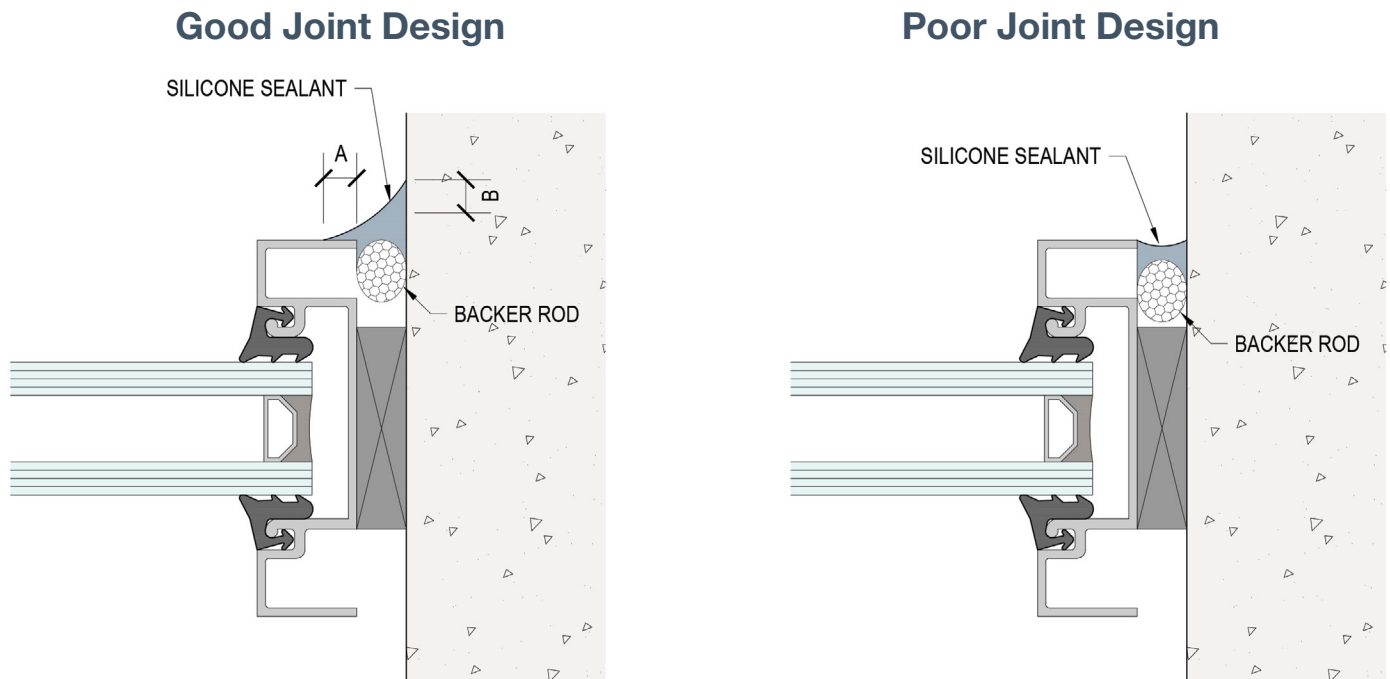

Good Joint Design – Key Points:

1. Dimensions A and B (sealant contact widths) are each 1/4" (6 mm) or larger.

Poor Joint Design – Concerns:

1. Attempting to apply sealant onto the edge (or behind) thin gauge metal results in inadequate sealant/substrate contact and water leakage.

Weatherproofing Joints: Surface Preparation and Sealant Application

Introduction

This application procedure outlines general requirements for installing DOWSIL™ Silicone Building Sealants. By following these procedures closely, you will help ensure good sealant performance. To be eligible to receive a Dow warranty, these procedures must be followed. Since DOWSIL™ Silicone Building Sealants are applied in many different environments and situations, these procedures are not intended to be a complete and comprehensive quality assurance program.

Field adhesion tests are required to help ensure good sealant performance and to verify any sealant recommendation (see the Quality Assurance section on p. 65).

There are five basic steps for proper joint preparation and sealant application:

1. **Clean** – joint surfaces must be clean, dry, dust-free and frost-free
2. **Prime** – if required based on testing, primer is applied to the clean surface(s)
3. **Pack** – backer rod or bond breaker is applied as required
4. **Seal** – sealant is applied by pushing the bead into the joint cavity.
5. **Tool** – dry tooling techniques are used to create a flush joint and to make certain the sealant has the proper configuration and in full contact with the substrate joint walls

Substrate Cleaning Procedure

The key to good sealant adhesion is a clean surface. You should always check with the supplier of the substrate to ensure that the cleaning procedures and solvents are compatible with the substrate.

Organic Solvent Usage

Not every solvent effectively removes every contaminant, and certain solvents can damage some substrates. Please follow the solvent manufacturer's safe handling recommendations and local, state and national regulations regarding solvent usage.

Non-Porous Substrates and Solvent Choice

Non-porous surfaces must be cleaned with a solvent before the sealant is applied. The solvent used will depend on the type of dirt or oil to be removed and the substrate to be cleaned. Non-oily dirt and dust can usually be removed with a 50% solution of isopropyl alcohol (IPA) and water, pure IPA, or methylated spirit. Oily dirt or films generally require a degreasing solvent such as xylene or white spirit. White spirit should be a minimum of 98% pure to help prevent leaving of an oily film on the substrate surface. MEK and toluene are also acceptable solvents. We do not recommend using denatured alcohol as a cleaning solvent.

Porous Substrates

Building materials such as cement board panels, concrete, granite, limestone and other stones or cementitious materials that absorb liquid are considered porous substrates. Dusting alone may be sufficient cleaning for new porous substrates. Depending on the condition of the surface, porous substrates may require abrasion cleaning, solvent cleaning or both. Laitance and surface dirt must be completely removed. Concrete form-release agents, water repellents and other types of surface treatments, protective coatings and old sealant all affect sealant adhesion. Removal of these treatments, coatings or sealants by abrasion cleaning may be required to obtain acceptable adhesion.

Abrasion cleaning involves grinding, saw cutting, sand or water blasting, mechanical abrading, or a combination of these methods. When choosing an abrasion cleaning method, it is important to choose one that will not leave a residue on the substrate. For example, some metal wire brushes can leave a varnish on precast panels. Remaining dust and loose particles should be removed by dusting the surface with a stiff brush, vacuuming, or blowing the joints with water- and oil-free compressed air. Once the abraded surface is clean and dry, the sealant can be applied. If the surface is dirty, it must be solvent cleaned with the two-cloth method explained later in this section. Some porous materials will trap solvents after cleaning or priming. Allow this solvent to evaporate before sealant is applied.

Please note that Dow's recommendations for removal of existing sealants, substrate cleaning, joint preparation and installation of DOWSIL™ sealants are not intended and may not be appropriate for remedial work involving existing sealants and/or joints containing polychlorinated biphenyls (PCBs) or other potentially hazardous substances. If you know or suspect that the existing sealants and/or joints contain PCBs or other hazardous substances, contact a knowledgeable authority on appropriate removal, handling and disposal procedures.

Two-Cloth Cleaning Method

Clean, soft, absorbent, lint-free cloths, along with the appropriate choice of solvent, must be used. The “two-cloth” cleaning method consists of a solvent wipe followed by a dry cloth wipe to lift and remove the solvent and contaminants suspended in the solvent. Multiple cleanings may be required to properly clean a substrate.

Organic solvent must be removed with the dry cloth before the solvent evaporates, or the cleaning will be less effective. Some porous surfaces or weather conditions will allow a small amount of residual organic solvent to remain in the top surface layer. If this is the case, the surface must be allowed to dry before installing primer (if needed), backer rod and sealant.

Cleaning Procedures for Flashing and Low Energy Surface Substrates

Peel-and-stick and spunbonded polyolefin substrates are unique surfaces to adhere to, and they must be clean to achieve sealant adhesion. However, adhesion to these substrates may be negatively affected if they are overcleaned, burnished or polished. Dow recommends a light two-rag wipe method using isopropanol alcohol (IPA) for cleaning these surfaces. Utilize clean, soft, absorbent, lint-free cloths for the cleaning. The two-cloth cleaning method consists of a solvent wipe followed by a dry cloth wipe.

The IPA must be removed with the dry cloth before the solvent evaporates, or the cleaning will be less effective. If any solvent remains on the substrate after the dry cloth wipe, allow the IPA to completely flash or dry prior to applying primer or sealant. Drying time depends on environmental conditions, but on a membrane substrate, allowing five to ten minutes for the IPA to flash off is typically sufficient.

Winter/Summer Solvent Considerations

IPA and MEK are water soluble and may be more appropriate for winter cleaning, as they help in removing condensation and frost. Xylene and toluene are not water soluble and may be better suited for warm-weather cleaning.

Cure Inhibition

DOWSIL™ 790 Silicone Building Sealant and DOWSIL™ Contractors Concrete Sealant are sensitive to alcohols. Therefore, when cleaning, Dow recommends using a non-alcohol based solvent and allowing the solvent to fully dry/flash prior to sealant installation. Primers must also be fully dry prior to sealant installation. Do not use alcohols or solvents as tooling aids with these sealants, as cure inhibition will result. Any application or contact of DOWSIL™ 790 Silicone Building Sealant and DOWSIL™ Contractors Concrete Sealant with alcohol, solvents or other uncured sealants may result in cure inhibition.

For more information on this topic, see Appendix A.

Primer Application Procedure

DOWSIL™ primers should be applied in the following manner and only to properly cleaned, dry and frost-free surfaces:

1. Apply masking tape to the surfaces next to the joint to keep excess primer and sealant off areas where they are not intended.
2. Pour some primer into a small, clean, solvent-resistant container; be sure to replace and tighten the cap on the primer can. To minimize deterioration of the primer, do not pour more than a 10-minute supply into the container. Primers need to be stored with the cap tightly closed, as DOWSIL™ primers react quickly when exposed to moisture, reducing their adhesion-promoting capabilities.
3. Depending on the substrate and job conditions, two different methods can be used to apply the primer. Dip a clean, dry, lint-free cloth into the primer and gently wipe a thin film onto the surface. For “hard-to-get-to” areas and rough surfaces, apply the primer in a thin film with a clean brush.
4. Allow the primer to dry until all the solvent evaporates. This typically takes five to 30 minutes, depending on the temperature and relative humidity.
5. Inspect the surface for dryness. Caution: Over-priming can cause adhesion loss between the sealant and the primer. If too much primer has been applied, a powdery, chalky, dusty film will form on the surface. Excess primer should be removed by dusting the joint with a clean, dry, lint-free cloth or a non-metallic bristle brush before applying the sealant.
6. The surface is now ready for application of the backer rod and sealant. Do Not Apply Primer Over Backer Rod. Applying primer over installed backer rod will cause an excess of primer accumulating at and within the backer rod, and 30 minutes will not be enough time for drying of the primer on the backer rod.
7. Sealant must be applied the same day surfaces are primed. Any surfaces primed but not sealed on the same day must be re-cleaned and re-primed before sealant application.

Sealant Application Procedure

It is critical that the sealant fills the entire joint or cavity and firmly contacts all surfaces intended to receive sealant. If the joint is improperly filled, adequate adhesion will not be achieved, and sealant performance will be impacted.

To obtain full adhesion, sealants require a clean, dry, frost-free surface. Although silicone sealants have excellent wide-temperature gunnability, the practical application temperature can be dictated by frost formation on the joint edges, which can begin to occur below 4°C (40°F). To assist in the drying of a frost-containing joint, a water-soluble solvent such as IPA should be used.

Sealant should be applied as follows:

1. To help ensure an aesthetically pleasing application, masking tape should be used to keep excess sealant from contacting adjacent areas where it is not intended.
2. Apply the sealant in a continuous operation using a caulking gun or pump. A positive pressure, adequate to fill the entire joint width, should be used. This can be accomplished by pushing the sealant ahead of the application nozzle. Care must be taken to ensure complete fill of the sealant cavity.
3. Tool the sealant with light pressure before a skin begins to form (typically 10 to 20 minutes). Tooling forces the sealant against the back-up material and the joint surfaces. NOTE: Do not use liquid tooling aids such as water, soap or alcohols. These materials may interfere with sealant cure and adhesion and create aesthetic issues.
4. Remove the masking tape before the sealant skins over (within about 15 minutes of tooling).

EIFS Application Guidelines

1. Allow the EIFS coating to dry a minimum of 24 hours prior to application of the DOWSIL™ sealant. The sealant joint should be applied to the base coat of the EIFS system. Do not apply sealant to EIFS finish coat unless approved by the EIFS manufacturer. Drying time may be greater, depending on temperature and humidity. Consult the EIFS manufacturer for recommended drying time.

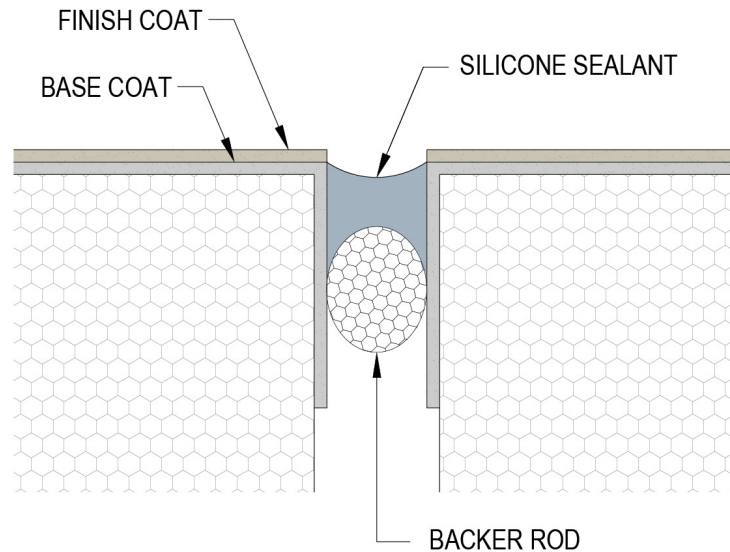

2. The joints must be clean and dry prior to installation of the DOWSIL™ sealant. If sealant is to be applied immediately following the drying time of the EIFS coating, simply brush or wipe the joint surfaces to ensure that there is no dust or debris in the joint. If the fully dried coating is exposed for greater than one day, joint surfaces must either be wire brushed or blown with oil-free compressed air or cleaned with a suitable solvent such as IPA using the two-cloth cleaning method. Consult the EIFS manufacturer to determine if a specific solvent is compatible with its system. Allow sufficient time for the solvent to evaporate prior to priming or installing sealant.
3. Lightly apply DOWSIL™ 1200 OS Primer or other recommended primer with a soft bristle brush to the inside of the joint. One brush wipe of the substrate should be sufficient. Follow primer application drying guidelines prior to backer rod installation.
4. Install either closed-cell polyethylene or non-gassing polyolefin backer rod with EIFS. Open-cell polyurethane backer rod should not be used adjacent to EIFS surfaces.

Removal and Replacement of Existing Weatherseals

Introduction

In some cases when an existing weatherseal condition is to be repaired or resealed, the existing weatherseal must be removed before a new weatherseal can be installed. When a failed organic sealant is to be cut out and replaced, the old sealant must be completely removed. When a silicone weatherseal is to be replaced with a new silicone sealant, complete removal of the existing functional joint may not be necessary.

Repairing Failed Organic Sealant with DOWSIL™ Silicone Building Sealant (Remedial Applications)

As buildings age, weatherseals may need to be repaired or removed and replaced. The replacement may be necessary due to the aging and deterioration of an organic weatherseal. If a sealant has been deemed to have failed, it is good practice to understand why it failed and replace it with a sealant offering higher-performance properties.

Please note that Dow's recommendations for removal of existing sealants, substrate cleaning, joint preparation and installation of DOWSIL™ sealants are not intended and may not be appropriate for remedial work involving existing sealants and/or joints containing PCBs or other potentially hazardous substances. If you know or suspect that the existing sealants and/or joints contain PCBs or hazardous substances, contact a knowledgeable authority on appropriate removal, handling and disposal procedures.

Before starting a project to replace or repair failed organic sealant, it is recommended to complete a mock-up demonstrating the procedures for removing the existing sealant and cleaning the substrates. Also, adhesion testing should be completed to determine whether a primer is required.

Follow this procedure to repair failed organic sealant with DOWSIL™ Silicone Building Sealant in remedial applications:

1. Cut away the old sealant as close to the joint edges as possible.
2. Clean all joints of contaminants and impurities to the depth at which the new DOWSIL™ Silicone Building Sealant and backer rod are to be installed. This may be accomplished by several methods: abrading with a wire brush (power or hand), grinding, saw cutting or solvent cleaning.
3. Blow out dust, loose particles and other debris with moisture-free and oil-free compressed air; 6.0-kg/cm² air pressure recommended; no moisture or oil allowed in air. Occasionally, a second pass with a wire brush and air blast is needed to ensure the joint is clean. Loose pieces of caulk or backer rod that have become lodged in the joint should also be removed.
4. After cleaning, the joints must be thoroughly dry, dust-free and frost-free before resealing.
5. Mask joint edges if possible to facilitate application and clean-up.
6. If priming is recommended, follow directions for applying the desired DOWSIL™ primer to the cleaned surfaces before installing the DOWSIL™ Silicone Building Sealant.
7. Install backer rod in joints to proper design depth.
8. Apply the appropriate DOWSIL™ Silicone Building Sealant in a continuous operation to properly fill and seal the joint width.
9. Using a blunt instrument, dry tool the joint so it is slightly concave. Tooling should be done as soon as possible after sealant application. Remove masking as necessary.
10. Seal a test joint and check adhesion after curing 7 to 21 days.

Removal and Replacement of Cured Silicone Sealant

A properly designed and installed silicone joint will typically last 20 years without need of replacement. In instances where the joint has experienced damage – mechanical or otherwise – and replacement is required, follow the procedures below.

Assess problem with the joint.

1. If sealant is cured properly and performing in its application but its appearance is poor (e.g., due to improper tooling), then cleaning the sealant surface with a solvent and recapping the joint should be sufficient.
 - a. Clean sealant with a solvent (e.g., xylene, toluene) to remove dirt. Allow solvent to evaporate.
 - b. Re-mask the joint.
 - c. Apply a thin bead of fresh sealant over the cured sealant.
 - d. Dry tool the sealant.
 - e. Remove the masking material.
2. If the sealant is mechanically damaged and a recapping will not improve the joint appearance, then remove the section of old sealant and replace.
 - a. Cut away the old sealant. If excellent adhesion to the substrate is still maintained, then leave some sealant at the edges of the joint (up to 0.08”/2 mm thick).
 - b. If adhesion to the substrate is poor, then remove sealant down to the substrate and clean the substrate and recondition if necessary (i.e., clean with xylene and prime with appropriate primer).
 - c. Mask the joint.
 - d. Reapply the sealant. If resealing does not occur on the same day, the joint will have to be recleaned using a solvent such as xylene or toluene before applying the fresh sealant.
 - e. Dry tool the joint.
 - f. Remove the masking material.
 - g. Check adhesion after sealant has cured for 7–21 days.

Sealing to Organic Air Barrier Membranes

Polyethylene-backed bitumen-based membranes are occasionally used as air barriers within exterior wall assemblies. Sealant materials are expected to adhere to the polyethylene backing to provide continuity of a watertight barrier at window and door openings along with various transition points within the wall. Polyethylene is known in the sealant industry as a bondbreaker because it is a low surface energy material that makes achieving adequate adhesion a challenge, and therefore the reliability of long-term bonding of the sealant unpredictable. One of the best options is the use of DOWSIL™ 758 Silicone Weather Barrier Sealant. With project-specific testing, other sealants may be suitable for the application such as DOWSIL™ 756 SM Building Sealant or DOWSIL™ 790 Silicone Weatherproofing Sealant, which may also require the use of a primer. Field adhesion testing should validate whether adhesion is adequate.

Many self-adhered and fluid-applied membranes will discolor light-colored sealants. Dow is available to test compatibility of flashing and sealant upon request. For any asphaltic or bitumen-based flashing material, Dow recommends a dark-colored sealant be used or the sealant be installed in a final nonvisible location. Typically, sealant performance is not affected by the discoloration on the sealant.

Resealing Corten Steel

DOWSIL™ weathersealants have been known to have limited weathersealing life when applied to Corten steel panels, due to continued corrosion of the steel at the bond line. This disintegration of the underlying substrate is excluded by the limited weatherseal warranty and has caused some hard feelings with contractors and consultants involved in repairing Corten steel-clad buildings.

High-performance coatings that act as corrosion inhibitors and primers may be used in these applications. Dow recommends that coating manufacturers be contacted for recommendations. Dow can complete adhesion testing on cured samples of specified coatings. DOWSIL™ 791 Silicone Weatherproofing Sealant or DOWSIL™ 795 Silicone Building Sealant have been successfully used in these applications.

Sealant Interaction Considerations

Dow Silicone Sealants are specifically formulated to offer durable performance in weatherproofing applications. They are commonly used with vastly diverse substrates along with potential variability in practices in the construction environment. Based on the highly developed reactive chemistries of our sealants there are unique situations that should be avoided. The following are important considerations specific to these instances.

Tooling Aids

The use of tooling aids is not recommended as they may impact the complex sealant chemistry and result in improper cure, reduced mechanical properties or other limitations.

DOWSIL™ 756 SM Building Sealant

DOWSIL™ 756 SM Building Sealant is a distinct chemistry of 100% silicone sealant allowing for reduced dirt pickup and a non-staining characteristic. DOWSIL™ 756 SM Building Sealant still requires stain testing to be completed and is not recommended for use with high iron content substrates.

Due to the distinct chemistry of DOWSIL™ 756 SM Building Sealant, certain stone types with high iron content have a potential to react with distinct components of this sealant and form a reddish-colored residue at the interface of the stone and sealant when in the presence of water and/or lack of sunlight. The residue formation should not be permanent nor construed as an irreversible staining process; typically, it can be removed with water or through natural exposure to the environment. Use of water and detergent with a soft bristle brush may accelerate removal.

Dow has developed a test to understand the residue potential between stone substrates and DOWSIL™ 756 SM Building Sealant and performs it on any submitted sample for stain testing. This test does not guarantee identification, but if an indication of residue is observed, the results will be communicated.

DOWSIL™ 756 SM Building Sealant may also display an aesthetic discoloration when NOT exposed to sunlight or when cured in confinement. This discoloration generally dissipates upon exposure to sunlight.

DOWSIL™ 758 Silicone Weather Barrier Sealant

DOWSIL™ 758 Silicone Weather Barrier Sealant is generally intended for use against polymeric flashing materials, which should be cleaned according to the procedures on p. 58. Once applied, avoid prolonged exposure to citrus containing cleaners, solvents and solvent-based cleaners. Generally, DOWSIL™ 758 Silicone Weather Barrier Sealant does not require use of a primer. **Should a primer be found to be necessary or to enhance adhesion, please follow the primer procedures on p. 60.**

DOWSIL™ 790 Silicone Building Sealant

DOWSIL™ 790 Silicone Building Sealant and DOWSIL™ Contractors Concrete Sealant are sensitive to alcohols. Therefore, when cleaning, Dow recommends using a non-alcohol based solvent and allowing the solvent to fully dry/flash prior to sealant installation. Primers must also be fully dry prior to sealant installation. Further, tooling aids should not be used, with particular emphasis on ones containing alcohols or solvents, as cure inhibition will result. Any application or contact of DOWSIL™ 790 Silicone Building Sealant and DOWSIL™ Contractors Concrete Sealant with alcohol, solvents or other uncured sealants may result in cure inhibition.

For more information on this topic, see Appendix A.

Skin-Over Time/Elastomeric Test

For one-part sealants, a skin-over time test and an elastomeric test should be performed once per week and on every new lot of sealant used. The purpose of this test is to check sealant working time and to help ensure the sealant cures fully. Any great variation (excessively long times) in the skin-over time may indicate an out-of-shelf-life sealant.

This test is performed as follows:

1. Spread a 0.04" (1 mm) thick film of sealant on a sheet of polyethylene or wax paper.
2. Every few minutes, touch the sealant film lightly with a tool.
3. When the sealant does not adhere to the tool, the sealant has skinned over. Note the time required to reach this point. If a skin has not formed within three hours, do not use this material; contact your Dow Representative.
4. Allow the sealant to cure for 24 hours. After 24 hours, peel the sealant away from the polyethylene sheet. Stretch the sealant slowly to see that it has cured. If the sealant has not cured, contact your Dow Representative.
5. Record the results in the Product Quality Control Log book. This testing must be completed and results recorded, retained and available for review upon request. A sample form is found at the end of this section.

Standard Field Adhesion Test

The field adhesion test is a simple screening procedure that may help detect application problems such as improper cleaning, use of improper primer, poor primer application or improper joint configuration. As a check for adhesion, a field adhesion test - a simple hand pull test - is required at the job site after the sealant is fully cured, usually within 7 to 21 days. Field adhesion testing should be documented using the Field Adhesion Testing Log. It is suggested that five tests for the first 1000' (300 meters) and one test per 1000' (300 meters) thereafter be submitted or one test per floor per elevation. The hand pull test procedure is as follows:

1. Make a knife cut horizontally from one side of the joint to the other.
2. Make 2 vertical cuts (from the above mentioned horizontal cut) approximately 3" (75 mm) long, at both sides of the joint.
3. Place a 1" (25 mm) mark on the sealant tab as shown in the illustration.
4. Grasp a 2" (50 mm) piece of sealant firmly just beyond the 1" (25 mm) mark and pull at a 90° angle.
5. If dissimilar substrates are being sealed, check the adhesion of sealant to each substrate separately. This is accomplished by extending the vertical cut along one side of the joint, checking adhesion to the opposite side and then repeating for the other surface. Pass/fail criteria for each sealant are shown in the following table. If the sealant does not pass according to the guidelines provided, consult your local Dow Representative or Distributor.
6. Inspect the joint for complete fill. The joint should not have voids, and joint dimensions should match those shown in the weathersealing details. A Dow Representative can assist in determining when corrective action is required.
7. Record the test results in a field adhesion test log. An example log is provided later in this section. This log will need to be retained as a part of Dow's warranty procedure. Some building officials and/or Authority Having Jurisdiction (AHJ may also require to receive these logs).

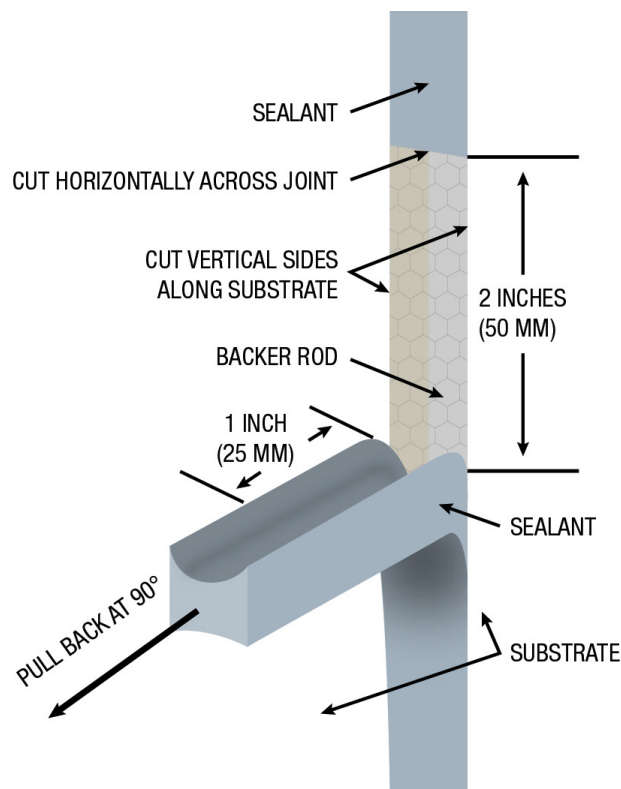

NOTE: When a sealant is used to weatherseal between two dissimilar substrates, it is recommended that the sealant adhesion to each side of the joint be individually tested, as noted in above Step 5.

NOTE for DOWSIL™ 758 Silicone Weather Barrier Sealant

When field adhesion testing with DOWSIL™ 758 Silicone Weather Barrier Sealant, please be aware of the distinct behavior of this sealant. No sealant should be pulled on at high speed, but in particular, DOWSIL™ 758 Silicone Weather Barrier Sealant should be pulled slowly at 90 degrees in order to avoid a false negative result.

Field Adhesion Hand Pull Test Criteria

DOWSIL™ Building Sealant	Adhesion Requirements
DOWSIL™ 790 Silicone Building Sealant	Pull tab 3" or 75 mm (300% extension) without bond loss
DOWSIL™ 791 Silicone Weatherproofing Sealant	Pull tab 1½" or 38 mm (150% extension) without bond loss
DOWSIL™ 795 Silicone Building Sealant	Cohesive failure: no adhesion loss
DOWSIL™ 995 Silicone Structural Sealant	Cohesive failure: no adhesion loss
DOWSIL™ 123 Silicone Seal	Cohesive failure of adhesive sealant: no adhesion loss
DOWSIL™ 121 Structural Glazing Sealant	Cohesive failure: no adhesion loss
DOWSIL™ 756 SM Building Sealant	Pull tab 1½" or 38 mm (150% extension) without bond loss
DOWSIL™ 758 Silicone Weather Barrier Sealant	Pull tab 2" or 50 mm (200% extension) without bond loss. NOTE: The pull should be completed slowly.
DOWSIL™ 983 Structural Glazing Sealant	Cohesive failure: no adhesion loss

Sealant Repair in Adhesion Test Area

Repair the sealant pulled from the test area by applying new sealant to the test area. Assuming good adhesion was originally obtained and observed through the adhesion test, use the same application procedure to repair the areas as was used to originally seal it. Care should be taken to ensure that the original sealant surfaces are clean and that the new sealant is in contact with the original sealant.

Peel-in-Adhesion Test Procedure

The Peel-in-Adhesion Test is another simple screening test can be done on a flat test surface. A test piece like that shown in illustration below is recommended.

1. Clean and prime the surface following the project-specific recommendations.
2. Place a piece of polyethylene sheet or bond breaker tape across the flat test surface.
3. Apply a bead of sealant and tool it to form a strip approximately 7.8" (200 mm) long, 1" (25 mm) wide and 1/8" (3 mm) thick. At least 2" (50 mm) of the sealant should be applied over the polyethylene sheet or bond breaker tape.
4. After cure of the sealant, pull the sealant perpendicular to the substrate until failure. Record the mode of failure and elongation of the test sealant.

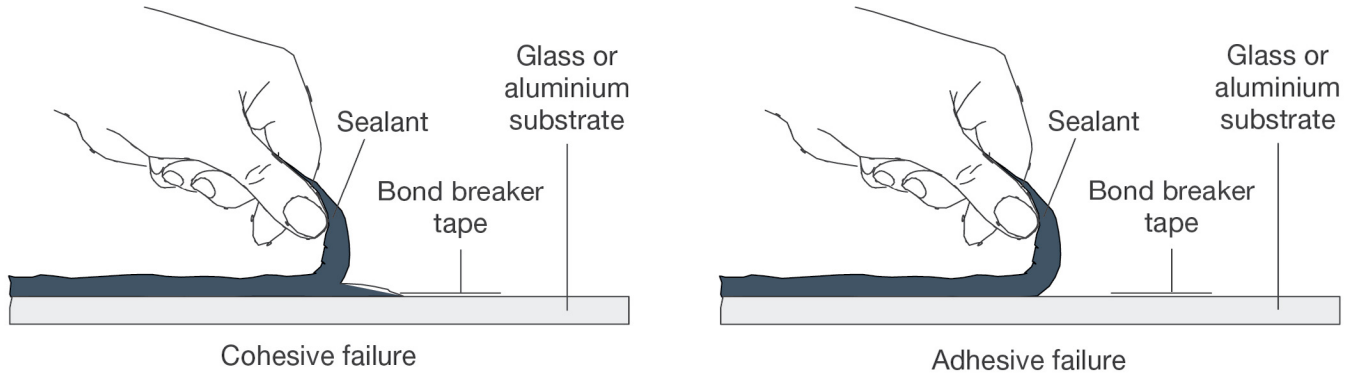

Suggested logs referred to in this section are provided on the following pages. In the event of a warranty claim or inspection, these must be available from the contractor, subcontractor or owner for review by Dow and/or the local building official and/or the Authority Having Jurisdiction (AHJ).

Therefore, it is suggested that these quality assurance logs be kept together with the project files. A hardcover or digital logbook may be preferential to copies of the logs suggested here. A quality professional should be responsible for documenting this data on a job-to-job basis. All curtainwall units must be numbered so the sealant installation dates, sealant lot numbers and quality assurance testing can be obtained from the project log.

Dow will be happy to assist you during the implementation of this quality control program. If you have any questions, contact your local Dow Building Science Sales or Technical Service Representative or authorized building sealant distributor.

Warranty – Weatherproofing Applications

All warranties are dependent on the successful completion of Dow requirements. These requirements include, and are not limited to, the following:

1. The sealant product(s) are applied within stated shelf life;
2. The sealant product(s) are applied in strict compliance with Dow’s published or electronic application procedures and, where applicable, any project-specific written recommendations from Dow;
3. The sealant product(s) are used with compatible materials and substrates. Testing/evaluation is required to obtain warranty;
4. Field adhesion tests are made, documented, retained and submitted to Dow upon written request, as outlined in our Field Adhesion Test Procedure, in order to confirm adhesion under site conditions.

At time of shipment, the DOWSIL™ sealant product(s) will meet the Dow sales specification. For further details on requirements and limitations of this limited warranty, consult the DOWSIL™ product data sheet for the sealant product(s) in use.

Dow also offers project-specific performance warranties for sealant products used in weatherproofing applications. These project-specific performance warranties carry various warranty terms (up to 20 years) and remedies. Specific requirements must be met to qualify for a performance warranty. Dow does not offer project-specific warranties on projects where wood is a primary substrate.

For details on how to obtain the applicable project-specific performance warranty, please consult your local Dow Representative or authorized building sealant distributor.

Quality assurance requirements for a performance, weatherproofing warranty include, but are not limited to:

1. Confirmation of adhesion is required for each substrate that contacts the approved DOWSIL™ weatherproofing sealant. Reference the Surface Preparation Guide within this manual (p. 7).
2. Field Testing documentation log book(s) show that a sufficient amount of testing was done. The minimum testing quantity is per ASTM C1521-02, Standard Practice for Evaluating Adhesion of Installed Weatherproofing Sealant Joints, section 7.3.3 which states:
“For each area to be inspected, perform procedure every 100 linear ft in the first 1,000 linear ft of joint. If no test failure is observed in the first 1,000 ft of joint, perform procedure every 1,000 linear ft thereafter or approximately once per floor per elevation.”
The contractor should determine other job-specific needs. The contractor should complete the log to demonstrate acceptable adhesion and joint design were obtained in actual use. This is in addition to the adhesion documentation noted in above item#1.
3. The contractor documents and retains all required quality assurance documentation and, upon completion of the project, provides a copy to the owner. This documentation must be retained for this warranty to be valid and will be required should any claims arise in the future. The owner must retain the quality assurance documentation along with the Dow-issued warranty.

Dow does not warrant aesthetics.

Appendix A: Cure Inhibition of DOWSIL™ 790 Silicone Building Sealant

Cure inhibition is a cause for concern in sealant applications. Moreso for DOWSIL™ 790 Silicone Building Sealant than for any other DOWSIL™ sealant.

DOWSIL™ 790 Silicone Building Sealant

DOWSIL™ 790 Silicone Building Sealant has a distinct chemistry that allows it to have exceptional primerless adhesion to porous substrates. It is also a low modulus, high movement capability (+100/-50%) sealant.

DOWSIL™ 790 Silicone Building Sealant's distinct chemistry also causes this sealant to cure slower than some other sealants, and this contributes to why we strongly suggest using an open-cell backer rod with this product when being installed against non-porous substrates. With the exception of EIFS, open-cell backer rod is preferable for DOWSIL™ 790 Silicone Building Sealant use on porous substrates as well.

Cure Inhibition

It is also this distinct chemistry that makes DOWSIL™ 790 Silicone Building Sealant especially susceptible to cure inhibition. A partial list of inhibiting items includes:

- Any alcohol – isopropyl alcohol (IPA), ethyl alcohol, butyl alcohol, etc. Alcohols may be used for cleaning but should be allowed to fully flash or dry prior to sealant installation. Use of alcohols as a cleaner on porous substrates is typically not recommended because it can be difficult to judge when the alcohol is fully flashed or dry.
- Many other solvents – acetone, methyl ethyl ketone (MEK), methyl isobutyl ketone (MIBK), etc.
- Solvent-containing materials – incompletely cured primers, incompletely dried paints, etc.
- Some kinds of release agents – solvent-containing products, materials containing glycols of any kind, etc.
- Many types of substrates – some EIFS products, some EPOXY substrates (any EPOXY material should be tested), any porous substrate cleaned with a solvent that has not had sufficient “flash-off” time, etc.

Conditions that should be avoided when working with DOWSIL™ 790 Silicone Building Sealant:

- **DO NOT** “wet tool” with solvents or soaps, as this can inhibit the surface of this sealant. The rest of the sealant bulk may cure normally, but the surface will remain tacky and gummy indefinitely.
- **DO NOT** apply this sealant to a backer rod that is contaminated with solvent or primer.
- **DO NOT** apply this sealant to a surface that has been cleaned with a solvent that has not been allowed to completely dry.
- **DO NOT** apply this sealant to EPOXY-containing surfaces unless they have been tested by the Dow Americas Construction Test Lab. They can inhibit the cure.
- **DO NOT** apply this sealant wet to wet with any of the other Dow branded sealants as they can inhibit the cure. Care should be taken to ensure a minimum of three to five days of the first sealant curing prior to installing the second sealant.

Appendix B: Use of DOWSIL™ Sealants with Weathered Lock-Strip Gasket Systems

Lock-Strip Wet Seal Joint

Good Joint Design

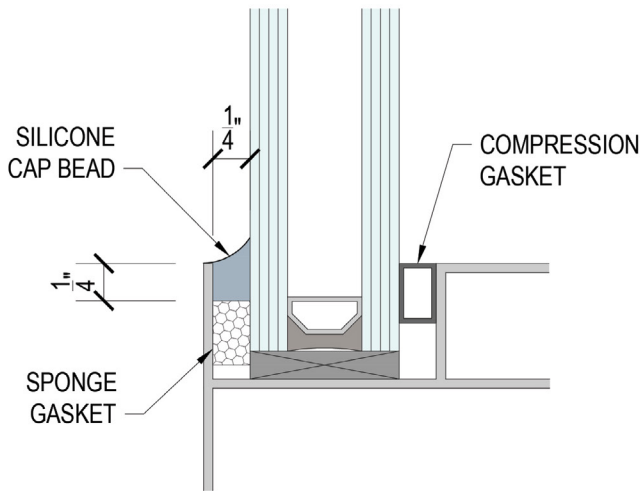

Poor Joint Design

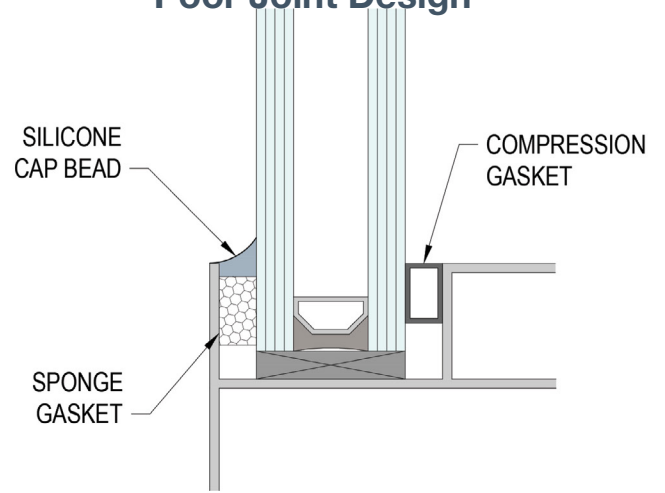

Good Joint Design – Key Points:

1. Both dimensions A and B are 1/4” or greater.
2. DOWSIL™ 791 Silicone Weatherproofing Sealant or DOWSIL™ 795 Silicone Building Sealant in a dark color is used with DOWSIL™ 1200 OS Primer on glass and lock-strip gasket.

Poor Joint Design – Concerns:

1. Insufficient sealant to accommodate movement.

Dow has evaluated sealants for use as a perimeter weatherseal for weathered and leaking lock-strip or zipper gasket systems. For the evaluation, various weathered gaskets aged 10 years and older were collected. DOWSIL™ sealants were tested for adhesion in simulated fillet bead wet seal joints for several thousands of hours of UV exposure and accelerated QUV weatherometer exposure. After this exposure, both DOWSIL™ 791 Silicone Weatherproofing Sealant and DOWSIL™ 795 Silicone Building Sealant have demonstrated excellent adhesion characteristics to the weathered gasket and glass.

As a result of this evaluation, Dow recommends the following steps to properly repair and seal leaking lock-strip or zipper gaskets systems using our silicone sealants:

- Use either DOWSIL™ 791 Silicone Weatherproofing Sealant or DOWSIL™ 795 Silicone Building Sealant. To minimize sealant discoloration from the gasket, use a dark-colored sealant.
- Solvent clean the glass and metal using the two-cloth wipe method described on p. 59.
- Prime both the glass and gasket surface to receive sealant with DOWSIL™ 1200 OS Primer.
- Perform a field adhesion test prior to job start-up and/or after application to verify proper sealant adhesion in job-site conditions.
- Install the sealant in a fillet bead with a minimum of 1/4” contact on both the glass and lock-strip gasket.

Appendix C: Winter/Summer Considerations

Silicone sealants can be applied in subfreezing temperatures, provided the substrate is frost- and moisture-free. Although cure will be slower in colder temperatures because colder temperatures generally have lower humidity levels, adhesion will be acceptable. DOWSIL™ 795 Silicone Building Sealant, DOWSIL™ 995 Silicone Structural Sealant, DOWSIL™ 756 SM Building Sealant, DOWSIL™ 791 Silicone Weatherproofing Sealant, DOWSIL™ 790 Silicone Building Sealant and DOWSIL™ 758 Silicone Weather Barrier Sealant have wider installation temperature ranges and are more suitable for use in cold temperatures than organic sealant technologies. DOWSIL™ one part sealants require moisture in the atmosphere to cure. The sealants will ultimately cure to the same physical properties as they do when applied in warmer temperatures. These DOWSIL™ sealants can be applied to substrates within a temperature range of -29 to 49°C (-20 to 120°F)¹. If lower or higher application temperatures are needed, please contact Dow to discuss appropriate sealants. IPA and MEK are water soluble and may be more appropriate for winter cleaning because they help in removing condensation and frost. Xylene and toluene are not water soluble and may be better suited for warm-weather cleaning. All surfaces must be free of moisture, condensation, morning dew and frost conditions prior to installation. (USE CAUTION WITH ALCOHOL-TYPE CLEANERS WITH DOWSIL™ 790 Silicone Building Sealant.)

At colder temperatures (below 4°C/40°F), substrates should be inspected for frost, which must be removed. An open flame is not recommended to dry the joints. This may leave hydrocarbon deposits and excess moisture on the surface that can impede adhesion. Do not dry the joints with a heater or blow dryer. Heating can cause moisture condensation to occur on metal once it cools. A moisture meter should be used to assure the substrates are dry before caulking; a control sample can be kept in the job office for reference if there are any questions. DOWSIL™ Silicone Building Sealants are not water based, so freezing temperatures will not cause the sealants to thicken excessively. This characteristic allows the sealants to be applied in cold weather. Daily inspections are strongly recommended to review these cold-weather conditions and correct with proper cleaning. Maintain a log, reviewing and recording low-temperature start-up conditions. Please allow longer curing time prior to performing field adhesion testing. Contact your Dow Application Sales Engineer for assistance.

At warmer temperatures (above 32°C/90°F), the solvent may flash prematurely and result in poor cleaning. Xylene and toluene are slower-drying solvents and may be preferred for cleaning warmer substrates.

No sealant should be installed immediately following or in anticipation of rain or snowfall. If unexpected snow or rain occurs, note it in the project log so field testing can be done on the potentially affected areas approximately two weeks later.

¹DOWSIL™ 995 Silicone Structural Sealant can be applied at temperatures up to 120°F. Refer to the product data sheet for more information.

Appendix D: Adhesion of Silicone and Polyurethane Sealants

DOWSIL™ silicone sealants will adequately adhere to cured polyurethane. It is important if polyurethanes and silicones will be in contact at a joint that the polyurethane is applied first and allowed to cure for approximately three days, depending on cure conditions. We recommend that DOWSIL™ 1200 OS Primer is applied to the cured polyurethane to help ensure adhesion of the DOWSIL™ silicone sealant.

Note that this procedure will not work in reverse. If the silicone is applied and allowed to cure for several days, the polyurethane sealant will not adhere to the silicone sealant. Also, the two materials, if applied wet to wet, will cure inhibit each other. Thus it is imperative that the order of installation is followed:

- Apply polyurethane sealant
- Allow time to cure
- Apply silicone sealant

The possibility for incompatibility between silicone and urethane sealants does exist. Laboratory evaluations based on ASTM C1087, Standard Test Method for Determining Compatibility of Liquid-Applied Sealants with Accessories Used in Structural Glazing Systems, will offer insight into this potential phenomenon.

For more information

Learn more about Dow's full range of building solutions, including service and support, at [dow.com/buildingscience](https://www.dow.com/buildingscience).

Explore our virtual city to learn about our performance-enhancing solutions at [dow.com/buildingscienceconnect](https://www.dow.com/buildingscienceconnect).

Dow has sales offices, manufacturing sites and science and technology laboratories around the globe. Find local contact information at [dow.com/contactus](https://www.dow.com/contactus).



Dow Building Science website:
[dow.com/buildingscience](https://www.dow.com/buildingscience)



Contact Dow Building Science:
[dow.com/customersupport](https://www.dow.com/customersupport)

 Visit us on X
[@DowBScience](https://twitter.com/DowBScience)

 Visit us on LinkedIn
[Dow Building Science](https://www.linkedin.com/company/dow-building-science)

Images: dow_42007349177, dow_40488794287, dow_40488794809, dow_40488795879, dow_40254511618, dow_48763602116, dow_48796230759, dow_70189938622

PRODUCT SAFETY INFORMATION REQUIRED FOR SAFE USE IS NOT INCLUDED IN THIS DOCUMENT. BEFORE HANDLING, READ PRODUCT AND SAFETY DATA SHEETS AND CONTAINER LABELS FOR SAFE USE, PHYSICAL AND HEALTH HAZARD INFORMATION. THE SAFETY DATA SHEET IS AVAILABLE ON THE DOW WEBSITE AT WWW.DOW.COM, OR FROM YOUR DOW SALES APPLICATION ENGINEER, OR DISTRIBUTOR, OR BY CALLING DOW CUSTOMER SERVICE.

NOTICE: No freedom from infringement of any patent owned by Dow or others is to be inferred. Because use conditions and applicable laws may differ from one location to another and may change with time, Customer is responsible for determining whether products and the information in this document are appropriate for Customer's use and for ensuring that Customer's workplace and disposal practices are in compliance with applicable laws and other government enactments. The product shown in this literature may not be available for sale and/or available in all geographies where Dow is represented. The claims made may not have been approved for use in all countries. Dow assumes no obligation or liability for the information in this document. References to "Dow" or the "Company" mean the Dow legal entity selling the products to Customer unless otherwise expressly noted. NO WARRANTIES ARE GIVEN; ALL IMPLIED WARRANTIES OF MERCHANTABILITY OR FITNESS FOR A PARTICULAR PURPOSE ARE EXPRESSLY EXCLUDED.

Users of this manual acknowledge and agree that Dow is not providing architectural, engineering or other professional services, and Dow assumes no responsibility for, and users of this manual are not relying on Dow for, any design, specifications, windload requirements, materials, samples, design elements, or testing of any design components, including the adequacy or completeness of the same, supplied or used by any warranty recipients or users of Dow products or services. Dow will only warrant products as set forth in a separate executed Dow warranty.

®™ Trademark of The Dow Chemical Company ("Dow") or an affiliated company of Dow

© 2024 The Dow Chemical Company. All rights reserved.

2000024823-7840

Form No. 62-1112-01-1124 S2D